



SPECIFICATIONS FOR BUS BODIES - 2023 CITY ORDINARY AND METRO EXPRESS

1.0 GENERAL DESIGN:

The general design shall be a streamlined body with two passenger entrances on LH side; one at front of front wheels another at rear of rear wheels without doors.

Sl. No	Description	Standards / Specifications
1	Type of Bus	Type-I Non-Deluxe with seating in 2x2 pattern as per TSRTC Specifications Model- City ordinary and Metro Express type bus bodies.
2	Chassis Models	11M - M 3 Category Bus Chassis
		1. AL VK2011-5639 mm WB with 60%ROH
		2. TATA LPO 1618/57- 5700MM WB with 60%ROH
		3. VECVL - 6016 -5840 mm WB with 60%ROH
3	Standards/ Regulations	The bus body design should comply with the provisions of latest Central Motor Vehicle Rules, Telangana State Motor Vehicle Rules and any other statutory requirement that may come in to force. Code of Practice for Bus Body:AIS 052.

2.0 MAIN DIMENSIONS: (ALL DIMENSIONS ARE IN MILLIMETERS)

SL NO.	CHASSIS MODEL -> DESCIPRTION	AL 222"WB	TATA 224"WB	EICHER 230"WB
1	Wheel base	5639	5700	5840
2	Rear overhang -max	3383 (60%)	3420 (60%)	3504 (60%)
3	Overall length- max	11287	10965	11549
4	Overall width -max	2590		
5	Pillar centers (std)	1130		
6	Window sill(waist rail) height from top of the cross bearer	610		
7	Waist rail height from skirt Level	1200		
8	Cant rail height from waist Level	1135		



Telangana State Road Transport Corporation

Mechanical Engineering Department: Musheerabad, Hyderabad -500020

9	Interior saloon clear height (Minimum) after finishing	1920	
10	Clear aperture of passenger service door (minimum)	Front -850; Rear - 900	
11	Clear aperture of driver door -minimum	650	
12	Seating capacity	City ordinary	46+1 Driver
		Metro Express	46+1 Driver

3.0 **DRAWINGS:** The list of drawings to be followed are shown at ANNEXURE-I.

4.0 **MATERIAL:** The fabrication of bus bodies shall be as per the specifications of material mentioned hereunder.

No	MATERIAL SPECIFICATIONS AND STANDARDS TO BE FOLLOWED	
Reference drawings Chart no. CB22GAE112 (sheet 1&2) containing the details of specifications and drawings for Aluminum extruded sections and Aluminum sheets.		
1	Aluminum Structural members	IS:733-1983 (or latest) for Solid Parts, IS:1285-2002 or latest for Extruded Round Tube and Hollow Part and IS:738-1977 or latest for Drawn Tubes, Alloy designation 63400,64430 &65032, Temper WP.
2	Aluminum Sheets	BIS:737-2008 (or latest), Aluminum Alloy Designation / condition-19000 Temper H2
3	Aluminum Chequered Sheets	BIS:737-2008 Alloy designation 65032, Temper WP
4	Aluminum Alloy Rivets, Aluminum Alloy multi grip blind rivets	Aluminum alloy wire of IS: 740-1977 or latest, Alloy designation 64430 (HR30-OD)
5	G.I. Tubular sections	BIS:4923-2017 (or latest) of Grade YST-310
6	CR sheets	BIS:513-2008(or latest)
7	GI Sheets	BIS:277-2018 (or latest),Class-VIII, Grade 175 grams/M2.
8	M.S Rolled sections	BIS-2062 of 2011 grade E-350, BIS-808 of 2021



Telangana State Road Transport Corporation

Mechanical Engineering Department: Musheerabad, Hyderabad -500020

9	ERW steel tubes	BIS: 3601: 2006 & BIS: 3074:2013
10	Galvanizing/ Anti corrosive coating	BIS:277- 2003 or latest - 175 grms for Galvanizing (Zinc Coating) and two weeks (336 hours) Salt Spray Test for both in accordance with ASTM procedure B117 with no structural detrimental effect to normally visible surfaces & no weight loss of over 1%. Zinc phosphate epoxy primer coating on structural members.
11	Stainless steel sheets	IS 6911:2017 AISI 304 Grade, Surface Finish-6
12	Stainless steel pipes	IS 6911:2017 AISI 304 (304 S1) Grade, Surface Finish-7
13	Upholstery	Vinyl coated upholstery fabric (Artificial leather) for seats - As per RDSO/2008/CG-07 IS-15061-2002
14	Poly Urethane Foam	Seat Bottom cushion - P.U Moulded foam conforming to Grade "J" Hardness- 35 to 50 at 50% deflection as per IS:8255-1976 (latest) , IS:7888-1976,IS-15061-2002 Seat Back squabs - P.U Moulded foam individual conforming to Grade "E" Hardness- 16 to 19 at 50% deflection as per IS:8255-1976 (latest) ,IS-15061-2002
15	Insulation	FR - grade, 4 mm thick cross linked closed cell polyethylene foam insulation laminated with Aluminum foil on one side. IS 15061-2002
16	EPDM Rubber	As per AIS 085
17	Glasses	Laminated Glass: BIS: 2553 (Part-2)-2019 (or latest), Wave free safety Float Glass, 0.76mm PVB Film interlayer. Toughened: BIS 2553 (Part-2)-2019 (or latest)
18	Paint	Automotive Paints as per relevant IS 2932-2003 (or latest) & any other relevant BIS Standards. Paint Gloss Value-above 71 units. Dry film thickness 110 Microns. Approved makes: Aspa range of Asian-PPG;



Telangana State Road Transport Corporation

Mechanical Engineering Department: Musheerabad, Hyderabad -500020

		Gallop range of ICI-Akzo Nobel. Self etch primer - as per IS:5666-1970
19	Ply wood	IS: 303 - 1989 conforming to Grade-MR, type-AA,
20	Automotive cables	BIS: 2465-1984(R2003) or DIN 72551/ISO6722
21	All Electrical lamps and fittings and wiper	AIS-012,AIS-034, AIS-052
22	PVC sleeve	IS 1951-1962
23	Piano switches	IS 9433-1980
24	Fuse Box	IS 4063-1982
25	Glass Cartridge fuses	IS 2577-2012/2018
26	Bolts and Fasteners	<p>All bolts used shall be of sizes reckoned in Metric system, High Tensile hexagonal head bolts of fine thread, conforming to property clause 8.8 of IS: 1367 of 1979.</p> <p>The nuts shall be approved anti-vibrative type such as nyloc conforming to IS: 1364 of 1983 shall be used.</p> <p>All bolts nuts and washers should be galvanized. Each bolt and nut shall be provided with a flat washer. A spring washer should accompany every tapped bolt.</p> <p>The approved brands of bolts are TVS/ STL/ UNBRAKO/IMPERIAL FASTENERS only.</p>
27	Body 'U' Clamps	IS 5517-1993- Shall be of EN-15/14B steel with tensile strength 80kg/sq.mm
28	Sewing thread makes	IS: 1720-1978- variety no.38, Make: "MODI/COATS"
29	Fire Extinguishers	IS 2171-1999 or IS 13849, Suitable for A, B & C class, 4 kg dry chemical type - E1
30	ELR Type Safety belts	As per AIS-052, AIS-023
31	Retro Reflective Tapes 50+10 mm width	AIS - 090-2018



Telangana State Road Transport Corporation

Mechanical Engineering Department: Musheerabad, Hyderabad -500020

32	MIG welding	IS 16003-2012 / ISO15607 : 2003
33	LED route Display Boards	As per AIS140

5.0 CHASSISPOSITIONING:

- 5.1 All chassis received by the firm for fabrication of bus bodies should be kept safely in a covered area. The chassis should not be kept open to atmosphere without any protection to avoid damage to chassis and its units due to rain, dust and heat.
- 5.2 Before commencement of bus body fabrication all important units of chassis viz. Alternator, self-starter, radiator, tyres and batteries should be protected by providing suitable covering to prevent from damages that may occur due to welding, drilling, cutting, hammering, riveting, falling of metal scrap or dust during the course of fabrication. Driver seats, steering wheel, hand brake valves etc., shall also be protected from any damage or paintspray.
- 5.3 Chassis number on long members and identification plates provided by the chassis manufacturer shall be properly covered and protected before commencing the fabrication work.
- 5.4 The Ashok Leyland, TATA and Eicher chassis are supplied with following items as OE fitment.

S. No	Description	OEM	Remarks
1	Cabin floor	On RH side	To be retained
2	Bulk head structure	AL,TML,EICHER	To be retained
3	Outriggers on LHS	AL,TML,EICHER	To be retained
4	Engine bonnet	AL,TML,EICHER	To be retained
5	Knitted Driver seat	AL,TML,EICHER	To be retained
6	Head lights 24v E2 with relays (AL)	AL,TML,EICHER	To be retained
7	Front indicatorsE2	AL,TML,EICHER	To be retained
8	Tail LampsE2	AL,TML,EICHER	To be retained
9	Battery cutoff switch	AL,TML,EICHER	To be retained
10	Wiper motor with twin blades/linkages	AL,TML,EICHER	To be retained
11	Washer tank with pipes	If supplied	To be retained
12	Reflective warning triangles with stands	AL,TML,EICHER	To be retained



Telangana State Road Transport Corporation

Mechanical Engineering Department: Musheerabad, Hyderabad -500020

13	Wheel stoppers	AL,TML,EICHER	To be retained
14	Spare wheel carrier winch type	If supplied	To be returned back
15	First aid kit	AL,TML,EICHER	To be retained
16	Tools as per CMVR	AL,TML,EICHER	To be retained
17	Rearview mirrors	AL,TML,EICHER	To be retained
18	Electrical horn	AL,TML,EICHER	To be retained

6.0 PROTECTIVE TREATMENT:

- 6.1 All Mild Steel components used for fabrication shall be carefully de-greased, de-rusted with three in one solution by dipping and wiped with dry cloth to remove all dirt/oil etc., Then the material shall be applied immediately (without any time lag) with Zinc Phosphate epoxy primer "Rust-O-Cap" (part no.24570608320) of M/s. Asian Paints or "60 BT PRIME GREY" of M/s Akzo-Nobel, to a thickness of 40 to 50 microns before assembly. All G.I Steel components used for fabrication shall also be carefully de-greased, de-rusted with three in one solution and wiped with dry cloth to remove all dirt/oil etc., After assembly of structure and completing the welding work, all the joints shall be carefully ground, cleaned and applied with Epoxy primer without any time delay and then complete body structure shall be applied with the above anticorrosive paint once again fully.
- 6.2 All Alu. Components shall be carefully cleaned with thinner. Self Etch primer paint shall be used at joints of dissimilar metals. The interior and exterior panels should be cleaned with thinner and then self etching primer shall be applied.
- 6.3 After completion of body assembly, bitumen based anti-corrosive, abrasive resistance and sound deadening property coating of Morrai Hydroban /3M /Sika shall be applied on the under floor body frame members, front end structure and chassis.

7.0 PRECAUTIONS:

- 7.1 Joints of structural members such as seat rail, crib rail, cant rail joints shall be provided with in wheelbase only.
- 7.2 All welding shall be done with MIG welding process only. Under any circumstances, arc welding is not allowed. Welding of Stainless steel components shall be done with TIG welding process only with same grade SS filler rod.
- 7.3 The following workmanship must be carefully followed during the fabrication.
- 7.3.1 All castings must be truly formed and free from blowholes.
- 7.3.2 All bolts and rivets should be well fastened



Telangana State Road Transport Corporation

Mechanical Engineering Department: Musheerabad, Hyderabad -500020

- 7.3.3 All welded joints must be chipped and well ground to get a smooth surface finish. All the welded joints shall be applied with Epoxy primer anti-corrosive paint immediately without any time delay to prevent the start of corrosion
- 7.3.4 Sharp corners shall be grounded and made smooth.
- 7.3.5 Wherever pitch for rivets / bolts is not specified, it shall be 100mm.
- 7.3.6 Bolt ends shall protrude at least 2 to 3 threads length above the nuts.
- 7.3.7 Roof stick, roof longitude, floor longitude and waist rail members shall butt properly at mating joints and shall not have gaps at the joints.
- 7.3.8 All tapping bolts such as grab rail, handles and assist rail bolts etc., shall be tightened using thread lock adhesive of approved makes.
- 7.3.9 All fixed glasses shall be provided with ceramic coating of suitable width on periphery.
- 7.3.10 Water Leak Test: Thorough water leak test shall be carried out before fixing weather shield strip or sealant and fixing the interior ceiling using pressurized water spray system. The fabricator shall equip water leak test facility conforming to IS: 11865/1982 at the firm for conducting leak test in two stages i.e., before fixing the interior ceiling and before dispatch of vehicle. At all stages the coach shall be water leak proof.

8.0 PARTICULARS OF IMPORTANT STRUCTURAL AND BODY MATERIAL:

Sl no.	Description	Material
1	Cross bearers	Rolled steel channel 100x50x6 (ISMC 100)
2	Anti sag bar	Rolled steel channel 75x40x6
3	Floor longitudes	G.I.'U' section-25x75x25x3.00 mm thick (5 rows)
4	All pillars and vertical members	G.I. tube 60x40x2 mm
5	Cant rail, waist rail, sole bar, intermediate rail and horizontal supports	G.I. tube 50x40x2 mm
6	Roof sticks and roof Longitudes, Diagonal supports	G.I. tube 40x40x2 mm (5 rows)
7	Crib rail and Seat rail	M.S. angle 40x40x3 mm
8	Skirt rail	M.S. angle 40x40x3 mm
9	Step edge beading	Indal 5701 section
10	Flat beading	Indal 5505 section



Telangana State Road Transport Corporation

Mechanical Engineering Department: Musheerabad, Hyderabad -500020

11	Decorative beading at a) Front end waist level b) Interior Waist Level & ceiling	a) Indal 2721section b) Indal 2684 section with plastic filler and ends
12	Window sections a) Window guide b) Sweep rubber section c) Fingerpull d) Split section1 e) Split section2	a) Hindalco 6482section b) Indal 2691section c) Indal 1752section d) T section - similar to Section 1671 of Satya Surya Alu.Ind. e) F section - similar to Section 1679 of Satya Surya Alu.Ind.
13	Wire casing	Indal 2735 section
14	Rub rail on body side	Indal 2676 section
15	Roof grab rail brackets	Indal 9638 of 30 mm wide black powder coated
16	Gussets for Cross bearer to Pillar joint	Galvanized MS plate of 6 mm 150mm length
17	JK door frame	G.I. tube 40x20x2 mm
18	RLB flap door and other flap door frame	G.I. tube 20x20x1.6 mm
19	Flap door hinge	Pin/bush type 12 mm OD
20	Body Panel-waist to floor level 610 mm	0.91mm Skin pass G.I. sheet
21	Body Panel- floor level to skirt rail	Aluminum sheet 1.22 mm thick
22	All flap doors	Alu sheet - 2 mm thick
23	Roof exterior panels	0.91 mm G.I sheet full length in three pieces with two joints on roof longitudes.
24	Roof interior	0.91 mm Alu sheet full width of bay
25	Flooring- Saloon, cabin, step well tread and All luggage booth floor	Aluminum 5 Bar Cheq. Plate -3.00 mm base thickness
26	Step well sides, riser All Luggage booth sides	0.7 mm stainless steel sheet
27	Mud wings	Stainless steel sheet 0.7mm thick, edges to be folded to avoid sharp edges
28	Cabin floor Structural members	ISJC 75x40 C-section, M.S. Angles 40x40x6 mm with M.S. Flat 40x6mm supports 'Z' riser G.I. sheet 3.00 mm
29	Front Bumper	CRCA sheet 1.6 mm pressed profile



Telangana State Road Transport Corporation

Mechanical Engineering Department: Musheerabad, Hyderabad -500020

30	Rear Bumper	CRCA sheet 2.0 mm pressed profile
31	Dash Board	0.91 mm G.I sheet
32	Truss panel	0.7 mm S.S panels from window sill to floor
33	Window finishers	0.5 mm S.S sheet
34	Stanchions	S.S. Round 38 mm OD x 1.6mm
35	continuous roof hand pole	S.S. Round 25 mm OD x 1.6 mm thick
36	Window guard rails	S.S. Round 20mm OD x 1.6 mm thick
37	Front wind shield glass	Single piece -curved Laminated windshield glasses - 8.76 mm thick with minimum 0.76 mm PVB film. Size : 2620/2435x1300 mm
38	Rear saloon glass	Single piece Toughened glass 5.0 mm thick - safety clear glasses. Size : 1760 x 800 mm
39	Shutter sliding glass size	Toughened glass 5.0 mm thick - safety clear glasses. Size : 600x540 mm
40	NEGATIVE TOLERANCES	“NEGATIVE TOLERANCES” are not allowed in Alu. extruded sections , Alu. Sheets, GI & SS sheets/tubes. However, tolerances within the limits of IS standards may be allowed subject to prior approval of the Chief Mechanical Engineer/TSRTC and cost recovery.

9.0 CABIN AND SALOON UNDER-FRAME STRUCTURE:

9.1 The cabin and saloon under frame structures of different make chassis shall be fabricated as per the respective drawings:

Chassis Model	City Ordinary	Metro Express
Ashok Leyland 5639mm WB	Drg.no.C2260UF23105	Drg.no.M2260UF23106
TATA 5700mm WB	Drg.no. C2460UF23304	Drg.noM2460UF23306
Eicher 5840mm WB	Drg.no. C3060UF23204	Drg.no.M3060UF23206

9.2 The OE cab floor, bulk head structure, out riggers/ anti sag bar, driver seat and engine bonnet. The OE structure shall be retained and modified accordingly to suit the fabrication.

9.3 If the chassis are supplied with bulkhead frame, it should be cut to suite the dash structure. The OE Cabin mountings shall be retained. The remaining portion of cabin floor connecting 1st-cross bearer and OE floor shall be fabricated as per the above drawings.



Telangana State Road Transport Corporation

Mechanical Engineering Department: Musheerabad, Hyderabad -500020

- 9.4 If the chassis are not supplied with Cabin floor, dash structure , engine hood and front end bulkhead, the same shall be fabricated during the fabrication of bus body
- 9.5 The dashboard frame shall be fabricated in MS angle 40x40x6 mm to the required profile and covered with GI sheet of 0.91mm thick. Flap door with suitable Stainless Steel hinges and Stainless Steel tower bolts shall be provided for easy access to fuse box, radiator and power steering reservoir.
- 9.6 The cabin floor shall be made in line with saloon floor except at wheels. The OE floor on RH Side of cabin shall be connected to the 1stcross bearer by providing a 'Z' riser in G.I. sheet 3.00 mm.
- 9.7 The cabin frame floor longitudinal members shall be connected to 1stcross bearer by MIG welding and with triangular gussets in 3 mm.
- 9.8 The OE anti-sag members shall be retained. If the chassis are not supplied with the anti-sag members a 3-piece anti sag channel in ISMC 75x40x6 mm shall be provided at front end of the chassis bottom frame connecting to the 'A' pillars on both sides duly making suitable changes.
- 9.9 Out riggers in M.S. angles 50x50x6 mm shall be provided connecting 'B' (2nd) pillars to the chassis long members by means of clamps made of M.S flat 50x6 mm
- 9.10 The wheel arch frames shall be made in rectangle shape fabricated in MS flat 40x6 mm and MS angles 40x40x6 mm shall be provided. The height of wheel arch box frame shall be 200 mm minimum from top surface of the tyre.
- 9.11 An inspection cover to be provided in saloon floor over fuel tank suction pipe of size 250x250 mm. Inspection covers shall also be provided at gear box and rear air suspension compound link area to facilitate maintenance.
- 9.12 The Saloon under frame: ISMC 100x50 Cross bearers should be mounted on the chassis web duly providing 6 mm (inverted pressed "L" type) M.S. plate as per the size shown in the respective drawings over the chassis long members. These "L" plates shall be bolted together to Long member web with M12x 50 H.T. bolts at least 4 nos. per plate. OE holes on the chassis long members shall only be picked up for mounting this plate. Wherever the holes are not matching holes shall be drilled on the web 40 mm below the top level of long member with prior approval. The length of bolt shall suit the depth of plate and chassis long member web thickness and should not project more than 6 mm after tightening the nuts.
- 9.13 The floor longitudes in five rows excluding crib rails should be welded to cross bearers as shown in the respective drawings. They should be arranged in such a way that the seat legs are fixed on the floor longitudes. Floor longitudes shall be provided wherever necessary for floor plate joints and for mounting stanchions.
- 9.14 The body mounting must be easily detachable from the chassis during major overhauls.

10.0 BODY STRUCTURE AND BODY MOUNTING:

The bus body side frame structure on RHS, LHS, Front end and Rear end should be fabricated as per the following drawings.



Telangana State Road Transport Corporation

Mechanical Engineering Department: Musheerabad, Hyderabad -500020

Chassis Model	City Ordinary Drg.nos.	Metro Express Drg.nos.
Ashok Leyland 5639mm WB	C2260SL23111, C2260SR23112 and C2260CS23115.	M2260SL23116, M2260SR23117 and M2260CS23120.
TATA 5700mm WB	C2460SL23311, C2460SR23312 and C2460CS23315.	M2460SL23305, M2460SR23306 and ME2460CS23120.
Eicher 5840mm WB	C3058SL23211, C3058SR23212 and C3058CS23215	M3060SL23316, M3060SR23317 and M3060CS23320.

10.1 Steel structural members:

The structural joints shall be by MIG welding in case of GI structural members. The welding should be for full length of joint. Welding slag to be removed and ground to smooth finish in order to avoid sharp edges.

- 10.2 The Side structure assembly on LHS and RHS shall be mounted on the Cross bearers duly by providing 6 mm G.I. plate as per the size shown in the respective drawings welded to the cross bearers and pillars.
- 10.3 Supports for panel fixing: Pressed G.I. 'L' section of 30x30x2 mm shall be provided on both sides of pillars and bottom of waist rails at truss panel area in order to rivet the truss panels. Pressed G.I. inverted 'L' section of 10x45x2 mm shall be provided below cant rail to weld roof panel ends and to support fixed glass fixing.
- 10.4 Galvanized M.S. tapping plates in 30x3 mm and 200 mm length shall be provided on Pillars for tapping and fixing window guard Rail brackets. Wherever Body components such as roof Hand poles, assist rails, driver partition, handles are fixed, tapping plates are to be provided in side structures and roof structure for fixing bolts.
- 10.5 The cant rail at the passenger entrance and driver door, emergency door shall be reinforced with G.I 40x40x2.0 mm thick tube and the cant rail joint should not be provided on any pillar or within door bays.
- 10.6 Cant rail bottom on both sides in between pillars shall be provided with MSL 30x30x3 mm for fixing hat rack brackets and roof panel, cant finisher fixing.
- 10.7 Front end structure shall be fabricated as per the respective drawings in M.S angle 40x40x6 mm frame with suitable opening for grill and provision for mounting head lamps, wiper, front bumper and other necessary fittings.
- 10.8 Rear end structure including rear end pillars and horizontal members shall be fabricated as per respective drawings.
- 10.9 The rear end saloon glass frame shall be in M.S. angle 30x30x3 mm welded to



the structural members.

- 10.10 An opening of size 250-mm x 250 mm, fabricated in M.S. angles 40x40x6 mm. the opening is to be finished with beading in Indal 5505 and a flap with ball catcher shall be provided at fuel oil tank mouth.
- 10.11 A separate compartment with flap door shall be fabricated around OE battery frame mounting in M.S.angles 40x40x6mmas shown in drawing.
- 10.12 Roof structure shall be as per the respective drawings in G.I.Tubes. All roof sticks formed to the profile shall be connected to the cant rail on both ends.
- 10.13 The chassis long members at the rear shall be retained while fabricating the bus body with 60% ROH. If the chassis are supplied with less than 60%ROH, then chassis long members are to be extended by providing 210 mm wide 6mm thick pressed C-section bolted to the chassis long members with M12 H.T bolts.
- 10.14 One more flap door on RHS cabin area shall be provided in BS-VI vehicles with vertical louvers for EATS equipment for maintenance and ventilation in AL vehicles. For TATA and EICHER vehicles suitable trap door in floor to be provided for inspection and maintenance of EATS system.

11.0 CABIN AND SALOON FLOOR:

- 11.1 The cabin floor shall be laid with 3 mm thick Alu.chequered sheet duly riveted with MS rivets of 5mm at a pitch of 75 mm to floor structural members, wheel arch frames and in zig-zag manner at joints. Dust proof rubber of 2mm shall be provided at joints and edges of the cheq. plate to avoid dust/ water entry into the bus. Alu.chequered sheet shall also be bolted to the under frame members with M6 size bolts at a pitch of 200 mm.
- 11.2 The saloon floor shall be laid with 3 mm thick Alu.chequered sheet duly riveted with M.S rivets of 5mm dia. to the floor longitudes and crib rail at a pitch of 100 mm and in Zig-Zag manner at joints. Intermediate bolting with M8 bolts shall be done on cross bearers and wheel arch frames.
- 11.3 Trap door of 580x 520mm must be provided in cabin flooring above gearbox. Trap doors in floor shall be finished with Aluminum extruded fluted strip section. Sunken type steel collapsible handles to be provided to lift the trap door.
- 11.4 Dust proof rubber packing of 2 mm of EPDM quality shall be provided at the joints and ends of chequered sheet to avoid entry of water / dust in to the saloon from the joints. The cheq.plate laying in floor shall ensure dust proof.
- 11.5 Four drain holes of 25-mm diameter and 75 mm length ERW pipe shall be provided in saloon flooring corners below seat frames for draining of water while washing.
- 11.6 The number of cheq.plates used for cabin and saloon flooring should be least in order to keep the joints at minimum possible. The floor cheq.plate shall be joggled at crib level to get proper seating.

12.0 BODY PANELING:



Telangana State Road Transport Corporation

Mechanical Engineering Department: Musheerabad, Hyderabad -500020

- 12.1 Stretch panel: The exterior portion of body from waist to floor level 610 mm wide and full length shall be provided with 0.91 mm G.I. skin pass sheet stretched in a fixture and welded to the side structure. P.U sealant shall also be applied on structural members to affix stretch panel. Stretch panel edges to be sealed with P.U sealant to avoid entry of water in to the structure.
- 12.2 The exterior portion of body from floor level to skirt, front end and rear end should be provided in Aluminum sheet 1.22 mm thick. The body panels shall be pasted to the structure on all vertical and horizontal members with approved make 'metal to metal' P.U. sealant duly maintaining a sealant bead thickness of 3 to 4 mm. Two sided 20 x 2 mm thick VHB tape of 3M make, 50 mm long - 6 nos. on each pillar to be pasted at equal spacing. The vertical butt joint of panels should be on Structural members.
- 12.3 The exterior panel ends on wheel arch and skirt rail angles shall be folded inside by 20 mm and should be fixed with flat beading and Alu. alloy CSK head solid rivets of 5.0 mm dia. at a pitch of 100mm. All joints and rivet ends to be finished to smooth surface by filling with P.U. putty.
- 12.4 The exterior body panels shall be riveted with CSK solid rivets on skirt rail and CSK blind rivets on first and last pillars and frond end and rear end pillars. No rivet shall be visible from outside.
- 12.5 Truss panel for body sides: Full height truss panel between waist to crib rail for entire length of body and at rear end including corners shall be provided in stainless steel sheet of 0.7 mm. These panels shall be riveted with 5 mm Alu. alloy solid rivets to the structural members at waist rail, pillars at a pitch of 100 mm. The riveting pitch on seat rail and crib rail shall be 100 mm.
- 12.6 Roof exterior panels: The exterior end/side panels (LH & RH) of roof have to be provided in single piece full length as required in 0.91 G.I sheet and welded tack welded to the roof structure. These tack welds are to be applied with sealant from inside.

The roof exterior sheet for center portion should be in full length of body and laid longitudinally in one single piece of 0.91 G.I sheet 1220 mm wide overlapping the side sheets. The overlapping joint of roof exterior center sheet and side sheet should be welded full length without any blow ups or burning.
- 12.7 Roof exterior panels shall be welded to the roof structural members intermittently to hold the sheet in position and shall be applied with P.U sealant on weld joints after shower test to prevent any water seepage.
- 12.8 The roof end/side sheets to be pre-formed to L-bend at cant level and to suite roof contour before assembling on the roof structure.
- 12.9 The front end and rear ends of roof are to be provided with FRP profile (dome) of 3 mm thick with overlapping joints on front most roof stick and cant and rear most roof stick and cant rail members. The overlapping joints shall be provided with Indal 5505 beading with CSK rivets.
- 12.10 In order to avoid any water leakage from overlapping portion of roof panel joints, overlapping portion should be provided with approved make weather shield strip of 150 mm wide and 1.2 mm thick with Alu.foil shall be laid longitudinally covering roof panel joints from front end to rear end to avoid



water leakage.

- 12.11 Interior of roof structure full width shall be provided with 4 mm thick cross linked closed cell polyethylene foam with aluminum foil lamination on one side for insulation.
- 12.12 Roof interior panels: The interior roof full width cant-rail to cant-rail should be in Aluminum sheet 0.91 mm thick
- 12.13 The overlap joint for roof interior ceiling panels should be on the roof sticks. The overlap of the roof panels should be equal to the full width of roof stick section and should be riveted by 4.76 mm dia. Alu.alloy multi grip blind rivets at a pitch of 100 mm. Riveting should be done on roof longitudes and cant rail also.
- 12.14 Interior ceiling panel joints on every roof stick, cant rail and on all sides of door openings shall be provided with decorative beading Indal 2684 with plastic filler and end covers.
- 12.15 The interior vertical finishers for pillars, horizontal finishers for windows at cant level, waist level and finishers for intermediate rail shall be in 0.5 mm stainless steel of 304 grade 'Type-7' finish. The finishers are to be pasted to structural members with PU sealants. There should not be any waviness in finishers and the sealant should not drip through the joints. All the horizontal finishers shall be in single piece per two bays and the overlap joints on pillars only. To avoid the exposure of sharp edges and waviness of the SS sheet used, the edges of the finisher is to be 'L' bent inside.
- 12.16 Alu.sheet 1.22 mm formed 'Z' section (size 25x40x25) shall be provided on waist rail which shall be riveted and pasted to waist rail duly overlapping on the exterior body panel at a pitch of 100 mm. The ends of 'Z' section shall be bent vertically upwards to overlap the pillar web. Ends and corners shall be applied with P.U. sealant to avoid seepage of water in to saloon.
- 12.17 An G.I .sheet formed 'Z' section (30x6x30) 1.6mm thick shall be welded to intermediate rail with Alu. flat head rivets of 5 mm to facilitate bonding of top fixed glass.
- 12.18 The body sides have to be provided with rub rail in Indal 2676 with EPDM rubber insert and end covers. The rub rail and ends shall be black powder coated.
- 12.19 The front end at waist level shall be provided with decorative beading Indal 2721. The beading shall be anodized and fixed with blind rivets and PVC filler. The rear end verticals, cant rail shall be provided with Alu. flat beading in Indal 5505 with CSK Alu. multi grip blind rivets.
- 12.20 The exterior corner domes both at front and rear on off side and near side from cant rail to waist and waist to skirt rail shall be provided in 0.91 mm G.I sheet over laid with Alu. sheet of 1.22mm thick and Indal 5505 beading on full length of pillars.
- 12.21 The interior panels shall also be provided with decorative beading in Indal 2684 at waist level with plastic filler, retention clips and end covers.
- 12.22 The area between exterior and interior panels from waist rail to crib rail in side structure shall be provided with 45 mm thick FR grade thermocole insulation.



12.23 Suitable flap doors shall be provided at Air Cleaner, Ad-Blue tank, Power steering reservoir and at EDC boxes with proper hinges and locks.

13.0 FOOT BOARD and PASSENGER ENTRANCE cum EXIT:

There shall be two Entrance cum Exits on LH side i.e., one in front of front wheels and another in ROH area as per the respective drawings.

The foot board structure at front and rear as shown in the drawing shall be in three steps built in MS. Angles 40x40x6 mm and over laid with Aluminum 5-bar chequered sheet of 3.0 mm base thickness on tread area. The Step well sides and riser portion should be provided with 0.7 mm SS sheet riveted to the structural members with M.S solid rivets together with step edge beading. The footboard should be given a support under the lowest tread by providing a 'U' type bracket made of MS angles 40x40x6 mm. The arms of 'U' bracket should be 230 mm long and welded to pillars. Step edge beading in Indal 5701 shall be provided along the edges.

The bottom tread height from ground shall not be more than 400 mm. The tread depth should not be less than 300mm. Maximum step height allowed is 250mm.

14.0 WHEEL ARCH FRAMES AND BOXES:

The rear wheel arch box frames should be fabricated in M.S angles 40x40x6mm and M.S flats 40x6 mm in rectangle shape as shown in respective drawings. The height of box frame shall be 200 mm above from the crown of the tyre. The boxes should be designed to accommodate 10R20 size tyres.

The rear wheel arch boxes shall be provided with 1.6 mm GI sheet on top, front, rear and on side and GI sheet is to be welded from bottom side to the frame. Alu. 5-bar chequered plate of 3.0-mm base thickness in single piece to be used for covering top, front & rear sides of wheel arch box frame. Side vertical portion to be covered in separate sheet with L-bending to overlap floor sheet. Step edge beading shall be provided at the riser and along the edges of wheel arch riveted with MS. Solid rivets \varnothing 5 mm.

Mud guard shall be provided in 0.7 mm thick S.S sheet full round along the wheel arch area with proper clamping and a clear gap of 150 mm (minimum) from the crown of the tyre.

15.0 DRIVER'S PARTITION:

The driver's partition shall be fabricated in 30x30x1.6 mm stainless steel tubes as per drg.no.CB23GDP114. It should be fixed behind driver seat and shall be supported on structural members with reinforcement in the floor as well as roof. The driver's partition shall be located as per seat layout drawing. A timing board of size 450x300 mm shall be provided in Alu.sheet 1.22mm duly painted white. The board should be provided in a sliding channel frame on 3 sides made of S.S. steel and fixed to the partition on



saloon side.

16.0 DESTINATION DISPLAY BOARDS:

16.1 The front and rear destination display shall be in LED boards.

16.2 The sizes of the destination LED display of boards:

Front : 1800 x 210 mm ; Rear : 1200 x 210 mm

16.3 The Destination Display shall be at roof centre as indicated in the structural drawings. The LED Destination Display boards shall be fitted to roof structure with suitable brackets bolted to tapping plates provided in roof structure.

16.4 The destination boards shall be visible clearly from front wind shield glass and rear saloon glass to the passengers from outside from a distance of 50 meter without any blockade.

16.5 Two side destination boxes shall be in 1st 1130 mm bay at window top fixed glass area, one behind front entrance and another in front of rear entrance. One flap door in 0.7 mm stainless steel sheet of size 1180 mm x 330 mm with SS piano hinge for full length at bottom and to be riveted to intermediate rail. Brackets in Indal 3620 are to be fitted on the inner face of the flap door for holding the destination board of size 910 mm x 210 mm. Two locking latches and chain for holding the flap from falling down shall be provided. This side destination board box frame should get flushed with the interior window finishers.

16.6 Two destination boards in G.I. sheet 0.91 have to be supplied along with the vehicle duly painted in white color.

16.7 LED destination display boards shall confirm to Specifications at Annexure - A.

17.0 CONTINUOUS ROOF HANDPOLE:

Three rows of continuous roof hand poles (grab rails) in stainless steel tube of 25 mm OD x 1.6 mm thick in 304 grades and 2B finish has to be provided as shown in seat layout drawing. The intermediate support brackets to be in Alu. extruded section Indal 9638 of 30mm width. These brackets are to be grey powder coated. These hand poles are to be provided with 28 nos. plastic moulded swiveling type hand holds - Arm slings with clamps and nylon ribbon in Grey color, two per bay. These pipes shall be joined together duly inserting a pipe of 100mm long into both pipes. (make of Arm Slings- Pacoline or any other make approved by TSRTC)

Sl.No	Type of bus	No.of Arm Slings
1	City Ordinary	E-28
2	Metro Express	E-28

18.0 WINDOW GUARDRAIL:

Two rows of guard rails in stainless steel tube in 304 grade of 20mm OD x 1.6



Telangana State Road Transport Corporation

Mechanical Engineering Department: Musheerabad, Hyderabad -500020

mm thick to be provided from outside on both sides of the vehicle at a height of 75 mm and 200 mm above waist level. The pipes shall be bolted to the pillars with M6 bolts with steel flat brackets as per drg.no.CB22GWG137. Tapping plates in MS flat 30x6 mm x 175-mm long duly galvanized shall be provided inside the pillar for fitment of guardrails.

19.0 CABIN FRONT WINDSCREEN, SALOON REAR GLASSES AND WINDOWS: REF DRG.NO: CB23GWS117

19.1 Front Wind Shield Glass Size: Single piece 2620/2435x1300 mm

19.2 The windshield glass frame assembly shall be made in MSL 25x25x3 mm to match the profile of the curved single piece windshield glass. The windshield frame shall be provided between front cant rail and dash structure duly welded on all sides. The complete frame from inside shall be covered with 0.5 mm stainless steel and outside to be covered with 1.22 mm Alu. sheet.

19.3 The Front curved Windshield glass shall be as per DRG.NO. CB23GWS117. The curved laminated glass shall be of 8.76 mm thick with minimum 0.76 mm PVB film and to be fitted with 57 mm EPDM synthetic rubber extruded section. The approved brands for glasses are DURASAFE, DURATUF, ATULTEMP, ATULSAFE, HIM and GSC. All corners of windshield glasses shall be provided with clamps in Alu. sheet 1.6 mm in black powder coating.

19.4 REAR SALOON GLASS: REF DRG.NO: CB23GGL118

Rear Saloon Glass size : Single piece glass 1760 x 800 mm size.

19.5 The saloon rear end glass as per DRG no. CB23GGL118 in 5.0 mm thick, toughened safety clear glass shall be bonded to the M.S. angle 30x30x3 mm frame provided in the rear body structure with PU sealant.

19.6 The lettering work to be done on the rear saloon glass and at cant level as mentioned below:

“BREAK THE GLASSES IN EMERGENCY FOR EXIT “

In Telugu:

" అక్కడనుంచి పరుగులు వేయండి " అని తెలుగులో వ్రాయండి

19.7 WINDOW FRAMES: REF DRG.NO : CB23GWA129

19.8

Description	City Ord	Metro Express
Window frame size in mm - Standard bay	1125 x 673	1125 x 673
Top fixed glass size	1127 x 450	1127 x 450
Sliding glass size in mm - Standard bay	600 x 540	600 x 540



Telangana State Road Transport Corporation

Mechanical Engineering Department: Musheerabad, Hyderabad -500020

All Glasses thickness in mm	5 .0 toughened float quality	5.0 toughened float quality
Glass tint	Clear	Clear

The window frames in Hindalco 6482 extruded section shall be provided between waist rail and intermediate rail and shall have two horizontal sliding glasses with flock channel of EPDM rubber quality. Window frames shall be black powder coated.

- 19.9 The top end of window frame shall be provided with split type section to facilitate replacement of glasses in case of damages.
- 19.10 The area between cant rail to intermediate rail shall be provided with fixed glass. The glass shall be bonded to the GI formed section on cant rail and flange of 'Z' in GI Sheet 1.6 mm thick on the intermediate rail by applying black P.U. sealant of approved make/ brand. The fixed glasses are to be secured intact.
- 19.11 The edges of all sliding glasses shall be ground, chamfered and polished to smooth surface. The tinted glasses shall conform to CMV Rules 11(2) for Visual light transmission.
- 19.12 All window frames to be provided with corner cleats in G.I sheet 30x1.22 mm- 200 mm length riveted with Alu. flat rivets besides welding at window frame corners. They should be fitted with M6x30 mm CSK head screws-2 nos. on each vertical side on pillars and -3nos. on intermediate rail. M.S. flat 30x6 mm tapping plates shall be provided on pillars and intermediate rail. Four drain slots of 50X3 mm shall be punched on side of window frame to drain out water collected in frame grooves.
- 19.13 All sliding glasses are to be provided with finger pulls in Indal 1752 section 100 mm long. The vertical side of glasses shall be provided with sweep rubber in Alu. section Indal 2691. These two sections are to be black powder coated.
- 19.14 Vertical overlap of window frames on pillars shall be provided with a sealing rubber profile as shown in the drawing.
- 19.15 Approved makes of EPDM rubber profiles are ASP/ALP.
- 19.16 Approved makes of P.U sealants are Total seal / Sikaflex / 3MIndia/ Henkel.

20.0 PASSENGER ENTRANCE, ASSIST RAILS:

- 20.1 The passenger entrance cum exits on LHS side as shown in the drawings.
- 20.2 At rear entrance on both sides of step well, assist rails in stainless steel tube 38 OD x 1.6 mm thick shall be fitted from roof stick to floor. The ends of these pipes are to be welded with S.S flats 50x3 mm and 100 mm long(430 grade) and bolted to the tapping plates provided in roof sticks at top and on cross bearers at bottom. Two horizontal support pipes and one diagonal support pipe in stainless steel tube 32 OD x1.6 mm thick shall be provided



Telangana State Road Transport Corporation

Mechanical Engineering Department: Musheerabad, Hyderabad -500020

on both sides of step well. There shall be rubberized belting packing between SS flats and roof/ floor etc.

- 20.3 At front entrance, assist rail in stainless steel tube of 32 OD x 1.6mm thick shall be fitted on both sides from cant level to floor. The ends of these pipes are to be welded with stainless steel flats 50x3 mm and 100 mm long and bolted.

21.0 DRIVER'S DOOR: Drg.no:CB23GDD113

The driver's cabin door from floor to intermediate rail with clear height of 1250 mm should have a window with full drop type two sliding glasses in window frame Hindalco 6482 section as per sketch no.CB22GDD113. The door shall have one heavy-duty door lock with outer handle, one S.S locking latch in 30x3 mm from inside tower bolt and dovetail catches. The door shall be fitted with two forged hinges on 'A' pillar. Driver door frame shall be provided with one horizontal bar in stainless steel 20x1.6 pipe from inside for holding. Interior paneling and finishers are to be made of SS steel sheet of 0.5 mm with scotch brite finish.

One S.S comode handle of 280 mm length is to be provided from outside on B pillar at Driver door.

22.0 PASSENGER SEATS:

The seat layout plan and seating arrangement shall be as per the respective drawings.

City Ordinary	C2260SG23114, C3060SG23314 and E2460SG23214
Metro Express	M2260SG23119, M3060SG23314 and M2460SG23214

22.1 SEAT FRAMES:

The seat frames for single, twin and triple seater shall be as per the respective drawings mentioned below. The legs of seat frames should be located on floor longitudes and seat rail only and shall be fastened with M8 hexagonal head H.Tbolts using plain washers and nyloc nuts. Belting fabric 3 mm thick (one piece) shall be provided in between the floor and seat leg foot piece. All seat frames shall be powder coated to smooth finish.

City Ordinary	CB23GSGSFP123
Metro Express	CB23GSFME122

22.2 SEAT BOTTOM CUSHIONS:

Seat bottom cushions shall be provided in P.U. moulded foam with a density between 35 to 50 kg / cu.m. The bottom cushion sizes shall be as follows:

Seat bottom	City Ordinary	Metro Express
Drawing no	CB23GSGSFP123	CB23GSFME122
Three seater	1200x380 x 90/65 mm	1240 x 406x 100/75 mm



Telangana State Road Transport Corporation

Mechanical Engineering Department: Musheerabad, Hyderabad -500020

Twin seater	813 x 380 x 90/65 mm	840 x 406 x 100/75 mm
Single seat	406 x 380 x 90/65 mm	406 x 406 x 100/75 mm

The cushions to be mounted on 8.0 mm thick ply wood with upholstery work in expanded vinyl coated fabric. The color shade of fabric shall be in charcoal grey and prior approval of CME shall be obtained for shade confirmation. The bottom plywood shall have 4 vent holes of 10 mm dia.per passenger seat. The bottom of plywood should be pasted with 1.0 mm thick ABS panel.

22.3 SEAT BACK SQUABS:

Seat back squab	City Ordinary	Metro Express
Drawing no	CB23GSGSFP123	CB23GSFME122
Three seater	1200X455X30mm	1240 x 406x 30 mm
Twin seater	813X455X30mm	840 x 406 x 30 mm
Single seat	406X450X30mm	406 x 406 x 30 mm

City Ordinary - The P.U moulded foam back cushions of 3 seater, 2 seater and single seats of sizes as per above drawing and conforming to grade “E” of IS: 8255-1976 shall be mounted on 8.0 mm thick plywood of grade - MR, type-AA, of IS: 303-1989 and upholstered with same expanded vinyl coated fabric mentioned above. The back of plywood shall be pasted with 1.0 mm ABS sheet of matching shade.

Metro Express- The P.U moulded foam back cushion of size as per the above drawing and conforming to grade “E” of IS: 8255-1976 shall be mounted on 8.0 mm thick plywood of grade - MR, type-AA, of IS: 303-1989 and upholstered with same expanded vinyl coated fabric mentioned above. The back of plywood shall be pasted with 1.0 mm ABS sheet of matching shade.

22.4 A sample seat shall be produced for approval of the Chief Mechanical Engineer before manufacturing in bulk and fitting in the vehicles.

22.5 All upholstery work shall be carried out with 3mm piping at all joints. A margin of 12 mm shall be provided for Rexene along the stitching lines and double stitching to be provided duly folding the Rexene edge by 6 mm. The tacking of Rexene to plywood to be by folding the Rexene by 12 mm with a pitch of 50mm in between nails.

22.6 The sewing thread makes to be used are “MODI/COATS”, variety no.38 as per IS: 1720-1978.

23.0 DRIVER’S SEAT:

The OE knitted/web type driver seats supplied with chassis shall be retained. The driver seat frame mounting on cabin floor shall match the OE mounting position.



Telangana State Road Transport Corporation

Mechanical Engineering Department: Musheerabad, Hyderabad -500020

- 23.1 In case of non-supply of OE knitted driver seat with the chassis, HDPE knitted driver seat of M/s. Uno Minda Industries (Harita Seating Systems) make approved by TSRTC shall be fitted. The seat shall have fore and aft, up and down adjustment of minimum 100mm with reclining back and to be fitted 350 mm away from steering wheel edge when the seat is fully forwarded.
- 23.2 The height of driver seat bottom shall be 450 mm when measured in fully lowered position.
- 23.3 There shall be a thigh clearance of 200 to 260mm between steering wheel edge and driver seating position
- 23.4 The driver seat shall be so located that the center line of driver seat shall be 705 mm away from the center line of body.
- 23.5 The driver seat shall be provided with “ELR” type safety belt of M/s. Autoliv or Rane make. (AIS 05).

24.0 BATTERYBOX:

The battery mounting provided by the OEM on chassis shall not be disturbed but a battery box enclosing the batteries shall be provided to prevent ingress of dust and water.

In case, the batteries temporarily fitted on chassis, a battery box shall be provide on LHS side below floor level to accommodate two 12V batteries of size 521Lx292Wx248H mm with slider arrangement.

The battery box compartment frame shall be fabricated in MSL 40X40X6mm and MS Flat 40x6 and to be paneled with 0.91 mm GI sheet on floor and three vertical sides. Acid resistant rubber shall be provided at the bottom of batteries.

OE battery cables harness and battery Isolator switch shall be retained. The terminals and cables should be firmly clipped in position. All Joints should be made dust proof. Suitable size opening in wall with rubber grommets shall be provided for passing battery cables and other wiring harness.

The flap door shall be provided with frame made in tubular section Alu. Sheet 1.6mm hinged on top with door lock and door seal rubber to prevent ingress of water and dust. A suitable stay bracket in M.S. rod 8mm should also be provided for flap door.

OE wiring harness shall not be tampered with under any circumstances.

25.0 ELECTRICAL WIRING AND OTHERFITMENTS:

- 25.1 The earth return system of wiring should be used. Wherever corrugated sleeve of FR grade carrying the cables have to pass through roof and side structures, PVC conduit of 12mmdia shall be provided. There shall not be any loose or hanging cables, and if they pass through holes in panels or structural members other than roof and side structures, rubber grommets shall be provided in the holes of such panels and structural members and



Telangana State Road Transport Corporation

Mechanical Engineering Department: Musheerabad, Hyderabad -500020

- shall be securely clipped as near as practicable to such rubber grommets to avoid chaffing.
- 25.2 Electrical wiring harness of TSRTC approved make for different circuits of saloon wiring shall be provided in the vehicle. In case of Body fabrication on old chassis retrieved from other buses chassis wiring pertaining to Body items to be provided during the fabrication.
 - 25.3 All saloon wiring shall be carried through Aluminum extruded section wire casing Indal 2735 in two rows along the cant rail offside and near side in such a way that it shall be easily accessible at all points without the need to strip major paneling of body. The extruded section shall be so located and fitted as not to affect the appearance of body.
 - 25.4 Any wiring, which has to run along the chassis frame shall be securely, clipped to ensure that there shall be no chaffing with any of the moving parts. Further care shall be taken to route such wiring in such a way that it is not subjected to splashing of oil, water, mud etc.,
 - 25.5 If required, the battery main cable of size 398/0.40 mm shall be used as required duly using good quality lugs with proper soldering, bolting and insulation etc., there shall be no joint in battery cables.
 - 25.6 All OE electrical fitments shall be retained and kept in working condition. Any extension of wiring harness should be done by providing male female connectors only. Tapping of power for saloon lighting etc., shall be taken from the OE female sockets provided by the chassis manufacturers. There should not be any tapping of power by slashing the main harness.
 - 25.7 Power for connecting Wiper, Indicators, Fog lamps shall be drawn from the sockets provided duly providing male / female sockets.
 - 25.8 Never connect the circuits with twists & knots. Never tap power by slashing the main harness.
 - 25.9 Cable ends shall be suitably crimped with lugs/soldered so as to withstand vehicle vibrations. The inter connections shall be made through couplers/ junction boxes / terminal blocks only. Weather proof connectors shall be used for connecting cables which are exposed to atmosphere to avoid water/moisture ingress during use.
 - 25.10 In the driver cabin Instrument panel with all gauges, OE switches & indicators with labels shall be provided at 45-degree angle and shall be in the reach of driver from his seat. The frame shall be fabricated in MS angle 25x25x3 mm covered with 1.22 mm thick GI.Sheet along with dash board panel.
 - 25.11 The following Electrical Lamps and accessories shall be fitted in the bus. All LED Lamps shall comply with the AIS specifications.

S.no.	Description	Requirement
1	Saloon and Cabin lamps	8 nos. of 390X130 mm LED Lamps of approved makes shall be provided as per layout drawing.
2	Step well lamp	One LED light assembly on the step



Telangana State Road Transport Corporation

Mechanical Engineering Department: Musheerabad, Hyderabad -500020

		well side wall with concealed wiring for foot board illumination
3	Conductor seat Lamp	One LED type light with separate switch
4	Destination board lamps	1 no .400 mm single row LED lamp for illuminating side destination board.
5	Wiper machine	OE electrical wiper machine with arms and blades supplied with the chassis shall be provided at cant level. In case wiper assemblies are not supplied with the chassis 17 W Lucas TVS electrical wiper machine with blade of 610 mm length (min) shall be provided by the fabricator.
6	Electric Horn	In addition to the OE electrical horn one more electrical horn conforming to type -2Bas per IS 1884- 1993 shall be provided. The horn shall be of single tone, water spray proof and noise levels should be between 93 dB to112dB.
7	Switches and Switch board	<p>Piano type switches and fuse box on Switch Board with hylam/decolam sheet of 3 mm thick shall be fitted above the driver door with non metallic shielding to avoid short circuits. A 6-pole disc type fuse box with independent fuse designated for every electrical circuit shall be fitted on switch board.</p> <p>Maximum current capacity of a circuit shall not exceed 15 Amps. The current carrying capacity shall be 1.5 times the load current of the electrical circuit.</p>
8	Head lamp assemblies	OE head lamp assemblies (4 nos) with suitable reinforcement to be retained. They shall be fitted at a distance not more than 400 mm from the extreme outer edge body and not more than 1200 mm height from the ground.
9	Direction indicator lamps	<p>Front end - Two OE lamps in amber color on the outer edge of body below 1500 mm height from ground.</p> <p>Body sides - Four LED type direction indicator lamps (flat type) in amber color at four wheels below 1500 mm height from the ground</p> <p>Rear end - Two OE lamps in amber color</p>



Telangana State Road Transport Corporation

Mechanical Engineering Department: Musheerabad, Hyderabad -500020

		on the outer edge of body below 1500 mm height from ground.
10	Height marker lamps	Front end - Two LED type lamps (flat type) in white color on the outer edge of body above wind shield glass. Rear end - Two LED type lamps (flat type) in red color on the outer edge of body above rear saloon glass.
11	Tail Lamps	Rear end - Two OE lamps in red color on the outer edge of body below 1500 mm height from ground. The red lamp shall have individual circuits for parking and brake lights.
12	Reverse Lamps	Rear end - Two OE lamps in white color on the outer edge of body below 1500 mm height from ground.
13	Rear number plate Lamp	LED lamp assembly of 300 mm length
14	One reverse gear horn	Shall be provided with noise level not more than 110 dB if not supplied with the chassis
15	Side flashers Lamps	Four nos.LED amber colour lamps at cant level on all four corners.
16	FM radio and Audio Speakers	Reputed make FM radio with built in pen drive port. Six nos.- Boston (Si-600) or Pioneer (TS 1641 GS) make, 6” size fitted in Hat rack with FRP speaker box with separate switch control for LH/RH side speakers.
17	TIM Socket	One 24V, 3-pin plug socket on the dashboard in driver’s cabin.
18	Electrical warning buzzer	One buzzer with 4 nos bell switches, one at conductor seat
19	Hazard warning signal switch	One in cabin, when operated all flashers should operate by the same switch
20	Audio announcement system	One microphone with one speaker audio output to outside passengers for informing passengers about service details shall be provided.
21	LB Lamps	Two LED lamps in rear luggage booth. One LED lamp in Battery box, two in Side luggage booths and one at Spare



Telangana State Road Transport Corporation

Mechanical Engineering Department: Musheerabad, Hyderabad -500020

		wheel carrier
22	LED destination boards	At front and rear as per specifications at annexure -C. <u>Size:</u> Front -1800 x 220 mm Rear - 1200 x 220 mm

26.0 BODY PAINTING AND COLORSCHEME:

- 26.1 Body to be painted on the exterior and interior with synthetic air-drying coach type enamel paints. The exterior painting process shall consist of carefully cleaning and etching followed by self etch primer coat, an under coat, finish coat and glaze coat.
- 26.2 Polyester putty of M/s AKZONOBEL or M/s Asian Paints shall be applied to cover rivet heads on beadings and on panel joints or to level any surfaces to prepare panels for painting.
- 26.3 The body under frame and chassis shall be painted with anti corrosive rubberized paint of specified make only.
- 26.4 Approved paint brands are: 'Auto-star' of M/s AKZONOBEL India Ltd., or 'Aspa' of M/s Asian Paints
- 26.5 Color Scheme - Color scheme should be as per sketch provided by the Corporation. The color scheme may be modified or changed at the time of execution of bus body fabrication as per the orders of Chief Mechanical Engineer.

Exterior paint:

Shade reference	City-Ord	Met Exp Type
Crystal white	AkzoNobel-199037	CO & MEXP
Satin black	AkzoNobel-199003	CO & MEXP
Dark Blue	Dupont-CF939	MEXP
Germaine red	AkzoNobel-199222	CO

Interior paint:

Shade reference	City-Ord and Met Exp Type	
Interior roof	Francoise white	AkzoNobel-199012
Dash Board	Grey Hammer tone	Grey Hammer tone
Destination boards, inside portion of boxes	White	AkzoNobel-199001



Telangana State Road Transport Corporation

Mechanical Engineering Department: Musheerabad, Hyderabad -500020

Seat No's 1 &2 Purple shade	RGB- 138:43:226 CMYK- 39:81:0:11 HEX- #8A2BE2	RGB- 138:43:226 CMYK- 39:81:0:11 HEX- #8A2BE2
--------------------------------	---	---

The color scheme may be modified or changed at the time of execution of bus body fabrication as per the orders of Chief Mechanical Engineer.

26.6 Lettering and Sticker work is to be done as detailed below:

- TSRTC website title: Book your tickets online: www.tsrtconline.in
Location: on top fixed glasses at LHS, RHS and Rear Saloon Glass in white radium sticker with Times new roman font in two rows.
- Labeling is to be done in red radium sticker for Emergency door, battery box, luggage booth, diesel tank, air cleaner and spare wheel.
- 'No smoking', 'No Chewing Gutkha / Pan Masala', 'No alcohol consumption' Labeling in red Sticker shall be provided in Telugu and English.
- Seat nos. as per lay out are to be exhibited in red radium sticker on 3mm Acrylic sheet (Size- 60x40 mm) to be fixed on window finisher. All lettering work in vinyl stickers shall be done as per the guidelines.
- 'TSRTC' in white radium sticker with Times New Roman font in 6"size is to be provided on front wind screen glass on top side.
- A slogan in Telugu shall be exhibited as follows on the partition wall

“ఈ బస్సు మనందరిది !
దీనిని పరిశుభ్రంగా వుంచుదాం !! ”

- TSRTC monogram shall be provided on both sides of body-380 mm (15") OD at center portion and rear panel -508 mm (20") OD as per SKETCH2316 printed with eco solvent UV inks on self adhesive vinyl sheet of 3M.

27.0 MISCELLANEOUS FITTINGS TO BE PROVIDED:

- Two Fiber handles of 100 mm size are to be provided at waist level of cabin front end.
- Two footsteps on the bumper shall be provided for cleaning of front windshield. Footsteps should not protrude outside the bumper.
- Two OE fully adjustable rear view mirrors of convex type supplied with chassis shall be fitted with brackets. The location of rear view mirrors shall be so located to have at least 2500 mm wide vision from the body line of vehicle when viewed from driver seat.
- One more small additional mirror shall be provided to RVM brackets to view front bumper area.
- One convex mirror to be fitted inside driver cabin.
- Provision for fixing HSRP registration plates shall be made at front and rear



Telangana State Road Transport Corporation

Mechanical Engineering Department: Musheerabad, Hyderabad -500020

side of body. The registration number shall also be painted on the right and left side of the body as per the CMV Rules,1989.

- 27.7 The registration number shall also be exhibited in saloon on front and rear destination boxes for the information of passengers.
- 27.8 One revenue permit board and one fitness certificate board of size 300x225 mm in Indal 3620 frame, glass and back plate in Alu.sheet 1.22 mm complete shall be provided on partition. The frames are to be black powder coated.
- 27.9 One fire extinguisher of approved make and dry chemical type 4.0 kg capacity suitable for 'A,B& C' class of fires shall be provided with suitable MS clamping arrangement in Driver's cabin.
- 27.10 Rubber mud splashguards of size 650x456 mm for rear and front wheels to be provided.
- 27.11 First aid box of Stainless steel in 310x220x128 mm size with leather straps and locking arrangement shall be provided in driver's cabin. First aid medicine kit containing the items mentioned under Rule 138(d)(4) of the latest M.V.Rules shall be provided in the box.
- | | |
|---|--------------------|
| i. Antiseptic cream of 5.0% centrimide I.P
In non-greasy base5mg | ...2pcs. |
| ii. Sterile Surgical gauge dressing | ...1 pack of 4pcs. |
| iii. Wash proof plaster | ... 5pcs. |
| iv. Sterile elastic plaster - size6cmx30cm | ... 1pc. |
| v. Gauge roll - size 7.5 cm x2.5mtr. | ... 3pcs. |
| vi. Elastic bandage for wounds and burns
Size - 8 cm x1.5mtr | 1pc. |
- 27.12 The rear bumper should be in GI sheet 2.0 mm thick-formed channel section of size 50x175x50 mm in single piece with brackets in MSL 40x40x6mm and to be fitted to the chassis long members. The ends of the bumper to be curved. The right side portions of bumper shall be made sunken to accommodate a registration number plate and number plate light.
- 27.13 The OE front bumper supplied with the chassis shall be retained. Front bumper length shall be increased to suite the body width i.e., 2590 mm. If the front bumper is not supplied with chassis, the bumper shall be fabricated in GI. sheet 1.6 mm of size 40x300x40 mm to suite the body width. The mounting shall be attached to chassis long members with M.S. angle 50x50x6 mm 400 mm long.
- 27.14 Two sunken footsteps of size 150x150mm shall be provided below the driver door one at 700 mm height from the ground and another at 950 mm.
- 27.15 The entrance door, driver door and emergency door shall be provided with water drain canopies at cant level in Alu.sheet1.22mm.
- 27.16 Pure rubber matting of 3.0mm thick shall be provided for foot control pedal



Telangana State Road Transport Corporation

Mechanical Engineering Department: Musheerabad, Hyderabad -500020

in driver's cabin.

- 27.17 A footstool for driver to be provided in Alu.5-bar cheq.sheet 3.00mm and Indal 2651 as legs. As shown in the drawing.noCB23GFS131.
- 27.18 Any Tapping of compressed air should be from port no.24 of system protection valve or auxiliary tank with proper unions, 'T' joints and copper coated Metallic/Teflon pipeline of 5.0-mm dia. The pipeline shall be firmly clamped in position.
- 27.19 One safe locker under twin seater for keeping conductor's cash, tickets etc., with locking arrangement shall be provided at 1ST Two seater frame.
- 27.20 One roller type sun visor of 24" size to be provided in driver cabin
- 27.21 Driver & engine bonnet to be separated from passengers by providing one row barricade in stainless steel pipe-304 grade in 32 OD x 1.6 mm thick with vertical supports and Steel sockets.
- 27.22 The seats earmarked for ladies, PHC persons, pregnant women/Lactating mothers, senior citizens are to be very clearly exhibited on seat backrests.
- 27.23 Retro-Reflective Conspicuity Marking tapes of 50 mm wide conforming to AIS: 90 of approved make shall be bonded to the body sides as per the sketch provided. The cumulative length of tapes provided shall not be less than 80% of length of that side. These tapes shall be white in color at front, yellow on sides and in red at rear of the body. The rear side of the body to provided red RRT vertically on both ends and at cant level and waist level.
- 27.24 Driver's cabin shall be suitably ventilated. One Alu. disc ventilator shall be provided below dash structure.

end



Annexure-A to Volume -III

LED Display Board Specifications as per AIS140:

1.1 Electronic route destination display system:

Alphanumeric Dual Display Technology colored LED based electronic route display system of high intensity illumination with automatic brightness control along with audio, video display system in English and Telugu shall be installed at the front, Rear and side of bus as per the following details.

1.2 Front Destination Board:

There shall be a display of destination with options in Telugu & English along with route number in alpha-numeric and via route information in alphabets. The display system shall be accommodated within the minimum size specified in the bus code. The display should be fixed type. The pitch of the LEDs shall be optimized to cover the maximum possible area along the length for displaying the maximum number of letters. The display shall be clearly visible in all weathers at a distance of up to 50 meters.

1.3 Specifications of LED Destination Boards:

- a. UV Resistant
- b. Operating temperature range -25⁰ C to 85⁰ C
- c. Relative humidity of upto 90%,
- d. Ingress Protection Grade of IP 65/55
- e. Cabinet shall be Powder Coated
- f. Amber color LED of 3.8/5.2 elliptical
- g. Non volatile memory in absence of power
- h. Dominant wave length - 591 - 595 nm
- i. Lens - UV Resistant diffused 4 mm size min
- j. Display language - English & Telugu

1.4 Features:

No	Description	Front LED
1	Display Size (Excluding Frame)	220mmX1800 mm (16rows x 96 columns) 220mmx1200mm (16rowsx 64 columns)
2	Display Type	Fixed / Scrolling / Alternate
3	Pitch	Max 13.4 x 14.1
4	Viewing Angle	Horizontal - Min 120 ⁰ and vertical - min 60 ⁰
5	Visibility	Minimum 50 Mts distance, all weather automatic brightness control in 50 steps
6	LED Intensity	400-700 mcd at 20 mA
7	Memory Capacity (Mini)	50 routes information with 50 destination names
8	Vibration	Vibration proof

end



Telangana State Road Transport Corporation

Mechanical Engineering Department: Musheerabad, Hyderabad -500020

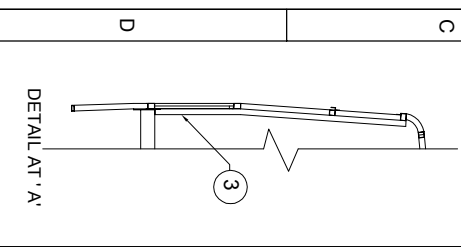
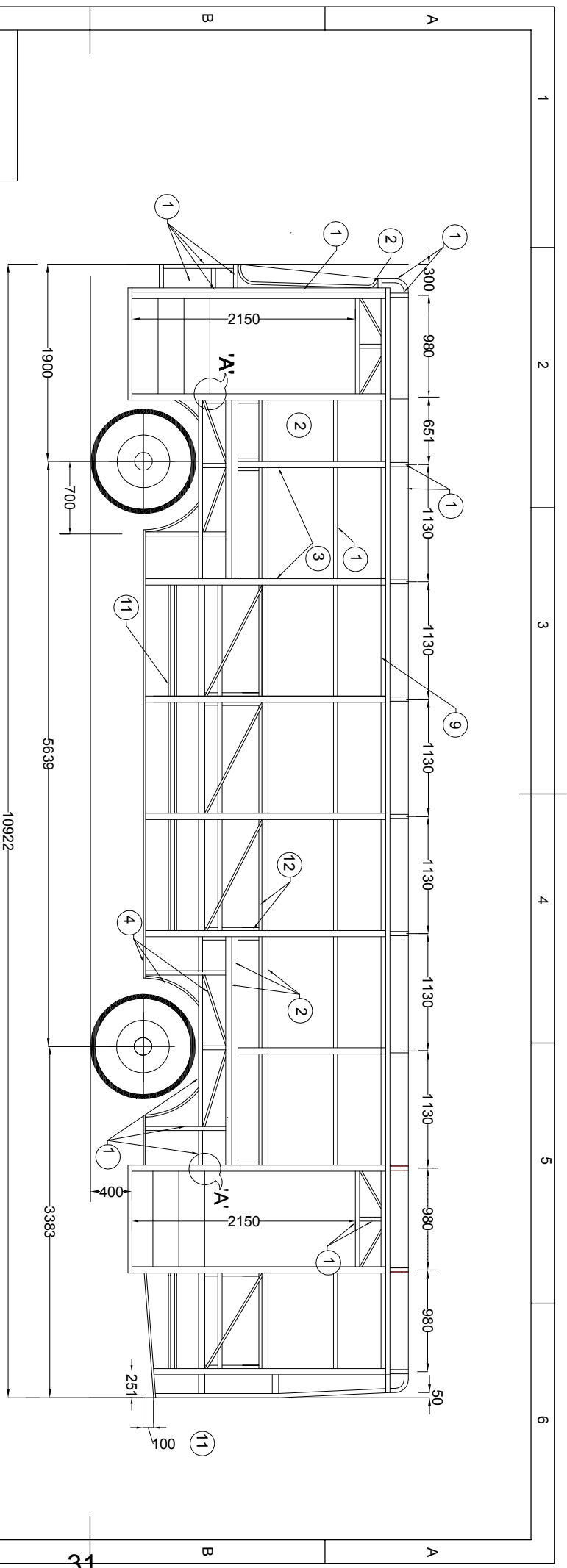

12.	GI FORMED SECTION 2 MM THICK
11.	GI FORMED SECTION 1.6 MM THICK
10.	MS PLATE 50 X 150 X6 MM
9.	FORMED GI L SECTION 10 X 45 X 2 MM
8.	FORMED GI L SECTION 20 X30 X 2 MM
7.	MSL 25 X 25 X 3 MM
6.	MSL 30 X 30 X 3 MM
5.	MSL 40 X 40 X 3 MM
4.	GI. RECT. TUBE 40 X 20 X 2 MM
3.	GI. RECT. TUBE 60 X 40 X 2 MM
2.	GI. RECT. TUBE 50 X 40 X 2 MM
1.	GI. SQ. TUBE 40 X 40 X 2 MM

S.NO	DESCRIPTION
12.	GI FORMED SECTION 2 MM THICK
11.	GI FORMED SECTION 1.6 MM THICK
10.	MS PLATE 50 X 150 X6 MM
9.	FORMED GI L SECTION 10 X 45 X 2 MM
8.	FORMED GI L SECTION 20 X30 X 2 MM
7.	MSL 25 X 25 X 3 MM
6.	MSL 30 X 30 X 3 MM
5.	MSL 40 X 40 X 3 MM
4.	GI. RECT. TUBE 40 X 20 X 2 MM
3.	GI. RECT. TUBE 60 X 40 X 2 MM
2.	GI. RECT. TUBE 50 X 40 X 2 MM
1.	GI. SQ. TUBE 40 X 40 X 2 MM

NOTE: USE OTHERWISE SPECIFIED DIMENSIONS ARE IN MILLIMETERS DO NOT SCALE DRAWING DEBUR AND BREAK ALL SHARP EDGES		TITLE	
DRAWN		SIDE STRUCTURE ASSEMBLY	
DESIGN.	CHECKED	APPROVED	SUB TITLE
D/SUP(Mech)	AME(C&B)	Dy.CME (C&B)	SIDE STRUCTURE LHS
DESIGN.	DATE	CHASSIS & ROH	CITY ORDINARY
SIGN.	DATE	SEATING	AL 5639 MM (222") WB & 60 %
REVISION	DATE	MATERIAL:	DWG NO.
		AS PER SPEC	C2260SL23111
			A4

1 2 3 4 5 6

10922

1900

5639

3383

WEIGHT:

SCALE:

SHEET 1 OF 1

NOTE : ADDITIONAL PILLAR IS TO BE PROVIDED AT BOTH ENTRANCES FROM CRIB LEVEL TO CANT LEVEL.

TELANGANA STATE ROAD TRANSPORT CORPORATION

SIDE STRUCTURE ASSEMBLY

C2260SL23111

A4

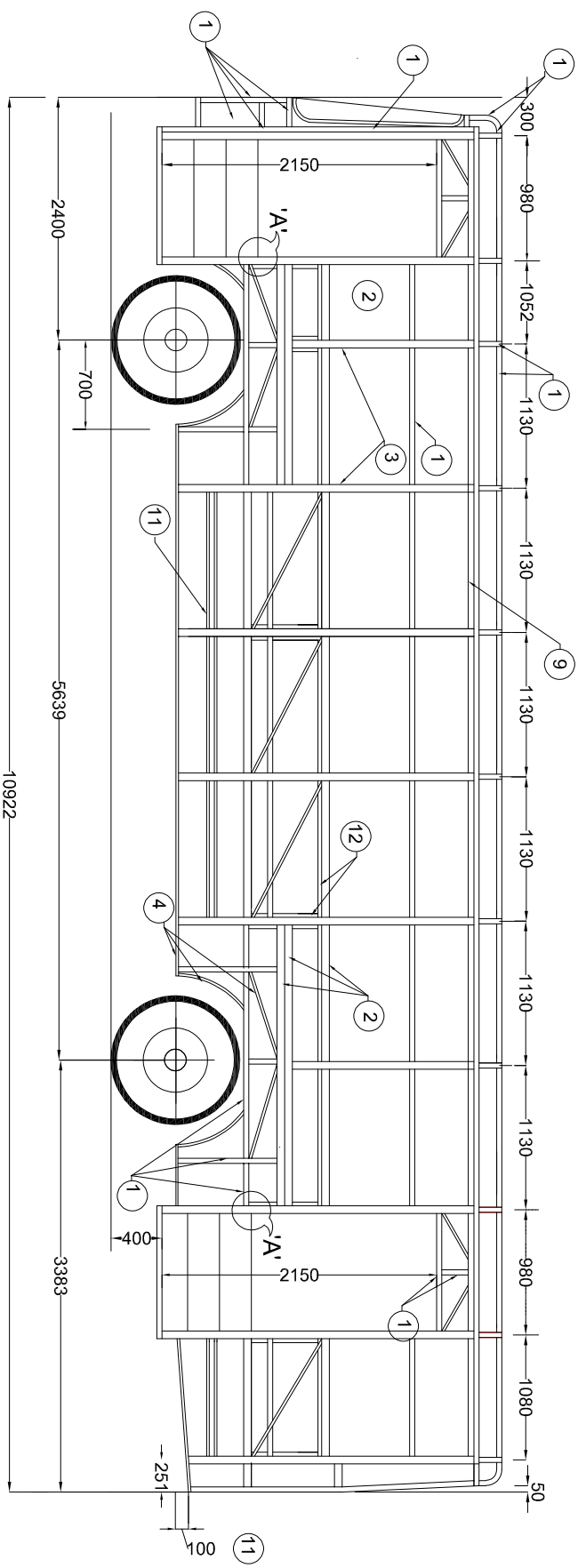

12.	GI FORMED SECTION 2 MM THICK
11.	GI FORMED SECTION 1.6 MM THICK
10.	MS PLATE 50 X 150 X6 MM
9.	FORMED GI L SECTION 10 X 45 X 2 MM
8.	FORMED GI L SECTION 20 X30 X 2 MM
7.	MSL 25 X 25 X 3 MM
6.	MSL 30 X 30 X 3 MM
5.	MSL 40 X 40 X 3 MM
4.	GI. RECT. TUBE 40 X 20 X 2 MM
3.	GI. RECT. TUBE 60 X 40 X 2 MM
2.	GI. RECT. TUBE 50 X 40 X 2 MM
1.	GI. SQ. TUBE 40 X 40 X 2 MM

NOTE: UNLESS OTHERWISE SPECIFIED ALL DIMENSIONS ARE IN MILLIMETERS. DO NOT SCALE DRAWING. DEBUR AND BREAK ALL SHARP EDGES.		TITLE	
DRAWN		CHECKED	APPROVED
DESIGN.	DY.SUP(MECH)	AME(C&B)	DY.CME(C&B)
SIGN.	DATE	CHASSIS & ROH	SEATING
REVISION		DATE	DWG NO.
DATE		AS PER SPEC	C2260SL23111
WEIGHT:		SCALE:	A4
4		5	6

NOTE : ADDITIONAL PILLAR IS TO BE PROVIDED AT BOTH ENTRANCES FROM CRIB LEVEL TO CANT LEVEL.

TELANGANA STATE ROAD TRANSPORT CORPORATION
SIDE STRUCTURE ASSEMBLY
SIDE STRUCTURE LHS
CITY ORDINARY

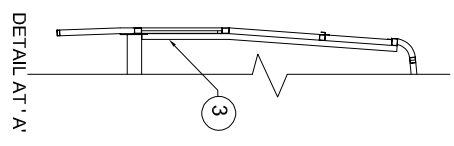

1 2 3 4 5 6

300 980 1052 1130 1130 1130 1130 1130 1130 1130 1130 1130 1130 1130 1130 980 1080 50

2150

2400 700 5639 10922 3383

2150

251 100

1 2 3 4 5 6

1 2 3 4 5 6

DETAIL AT 'A'

3

12. GI FORMED SECTION 2 MM THICK

11. GI FORMED SECTION 1.6 MM THICK

10. MS PLATE 50 X 150 X6 MM

9. FORMED GI L SECTION 10 X 45 X 2 MM

8. FORMED GI L SECTION 20 X30 X 2 MM

7. MSL 25 X 25 X 3 MM

6. MSL 30 X 30 X 3 MM

5. MSL 40 X 40 X 3 MM

4. GI. RECT. TUBE 40 X 20 X 2 MM

3. GI. RECT. TUBE 60 X 40 X 2 MM

2. GI. RECT. TUBE 50 X 40 X 2 MM

1. GI. SQ. TUBE 40 X 40 X 2 MM

S.NO DESCRIPTION

NOTE: UNLESS OTHERWISE SPECIFIED ALL DIMENSIONS ARE IN MILLIMETERS. DO NOT SCALE DRAWING. DEBUR AND BREAK ALL SHARP EDGES.

TITLE

DRAWN

CHECKED

APPROVED

DESIGN.

DY.SUP(MECH)

AME(C&B)

DY.CME(C&B)

SIGN.

DATE

CHASSIS & ROH

SEATING

REVISION

DATE

AS PER SPEC

DWG NO.

C2260SL23111

WEIGHT:

SCALE:

4

5

6

A4

1 2 3 4 5 6

1 2 3 4 5 6

1 2 3 4 5 6

1 2 3 4 5 6

1 2 3 4 5 6

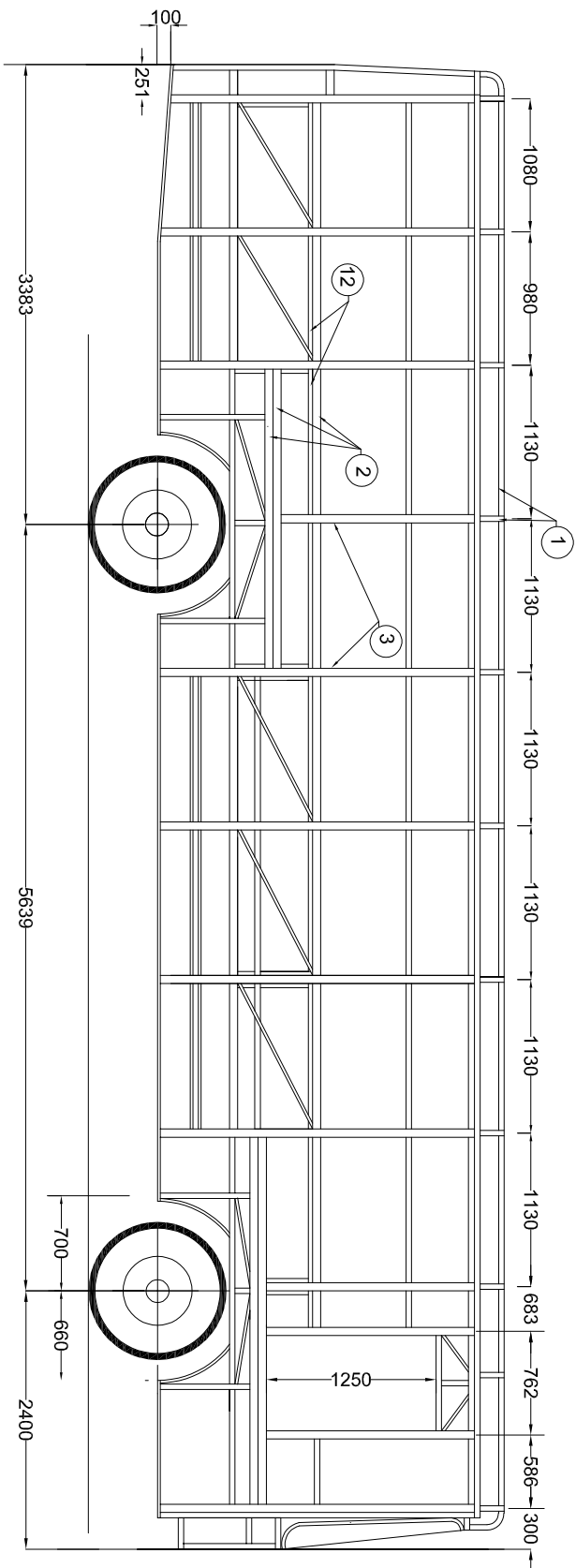



12.	GI FORMED SECTION 2 MM THICK
11.	GI FORMED SECTION 1.6 MM THICK
10.	MS PLATE 60 X 160 X 6 MM
9.	FORMED GI L SECTION 10 X 45 X 2 MM
8.	FORMED GI L SECTION 20 X 30 X 2 MM
7.	MSL 25 X 25 X 3 MM
6.	MSL 30 X 30 X 3 MM
5.	MSL 40 X 40 X 3 MM
4.	GI. RECT. TUBE 40 X 20 X 2 MM
3.	GI. RECT. TUBE 60 X 40 X 2 MM
2.	GI. RECT. TUBE 50 X 40 X 2 MM
1.	GI. SQ. TUBE 40 X 40 X 2 MM

TELANGANA STATE ROAD TRANSPORT CORPORATION

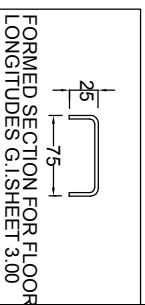
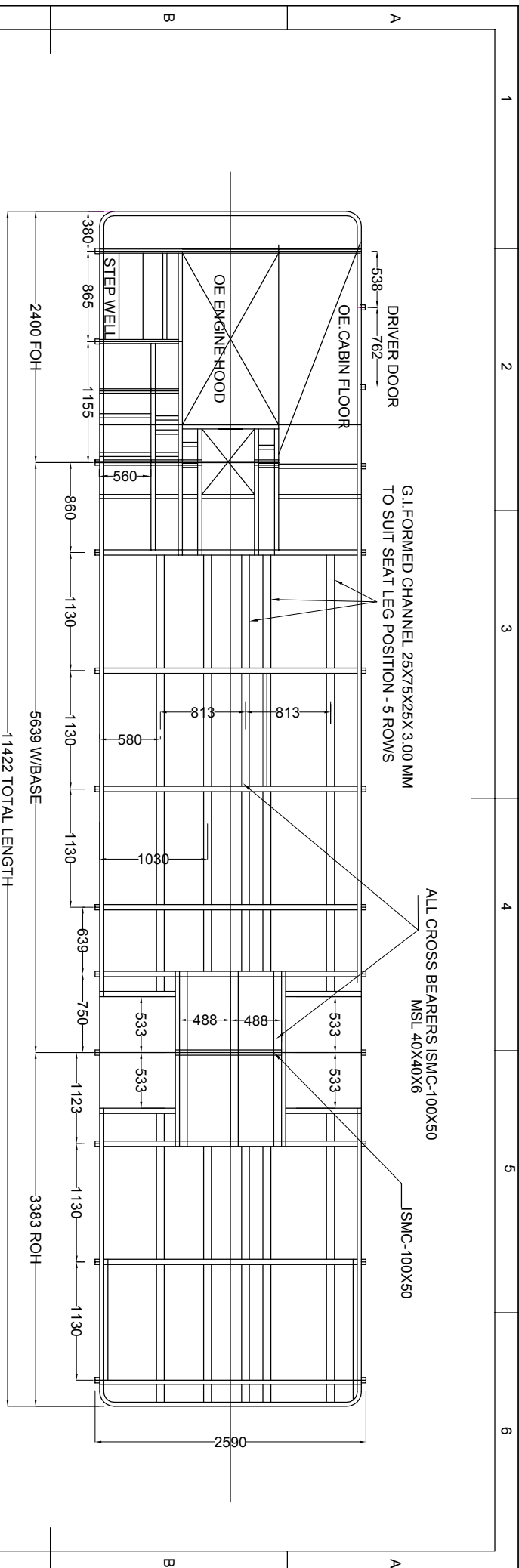
NOTE: UNLESS OTHERWISE SPECIFIED ALL DIMENSIONS ARE IN MILLIMETERS DO NOT SCALE DRAWING. DEBUR AND BREAK ALL SHARP EDGES		TITLE	
DRAWN		SIDE STRUCTURE ASSEMBLY	
DESIGN.	DYSUP(Mech)	CHECKED	AME(C&B)
SIGN.		APPROVED	DY CME (C&B)
DATE		SUB TITLE	SIDE STRUCTURE RHS
DATE		TYPE OF BODY	CITY ORDINARY
MATERIAL:		CHASSIS & ROH	AL 5639 MM (222") WB & 80 %
AS PER SPEC		SEATING	46 + 1 DRIVER
REVISION		DWG NO.	C2260SR233112
DATE		SCALE:	
		WEIGHT:	
		AS PER SPEC	
		DATE	
		DATE	



4. JOGGLE FLOOR CHECK SHEET AT CRIB RAIL ON BOTH SIDE
3. FABRICATE CABIN UNDER FRAME AS PER DRG. DULY RETAINING OE FLOOR
2. PROVIDE G.I. 75X75X3.00 MM TRIANGULAR GUSSETS AT ALL CORNERS IN CABIN FRAME
1. PROVIDE G.I.U. 25X75X25X3.00 MM SUPPORTS IN CROSS BEARER TO CONNECT FLOOR LONGITUDES

		TELANGANA STATE ROAD TRANSPORT CORPORATION		TITLE	
		UNDER FRAME ASSEMBLY		CABIN AND SALOON UNDER FRAME	
<small>NOTE: UNLESS OTHERWISE SPECIFIED ALL DIMENSIONS ARE IN MILLIMETERS DO NOT SCALE DRAWING. DASH AND BREAK ALL SHARP EDGES.</small>		DRAWN	CHECKED	APPROVED	SUB TITLE
DESIGN.	AE(Mech)	AME(C&B)	DY.CME (C&B)	TYPE OF BODY	CITY-ORDINARY
SIGN.		DATE		CHASSIS & ROH	AL 5639 MM (222") WB & 60 %
REVISION	DATE	MATERIAL: AS PER SPEC		DWG NO.	SEATING
1	2	3	4	5	6
WEIGHT:		SCALE:		SHEET 1 OF 1	
C2260UF23113		A4			

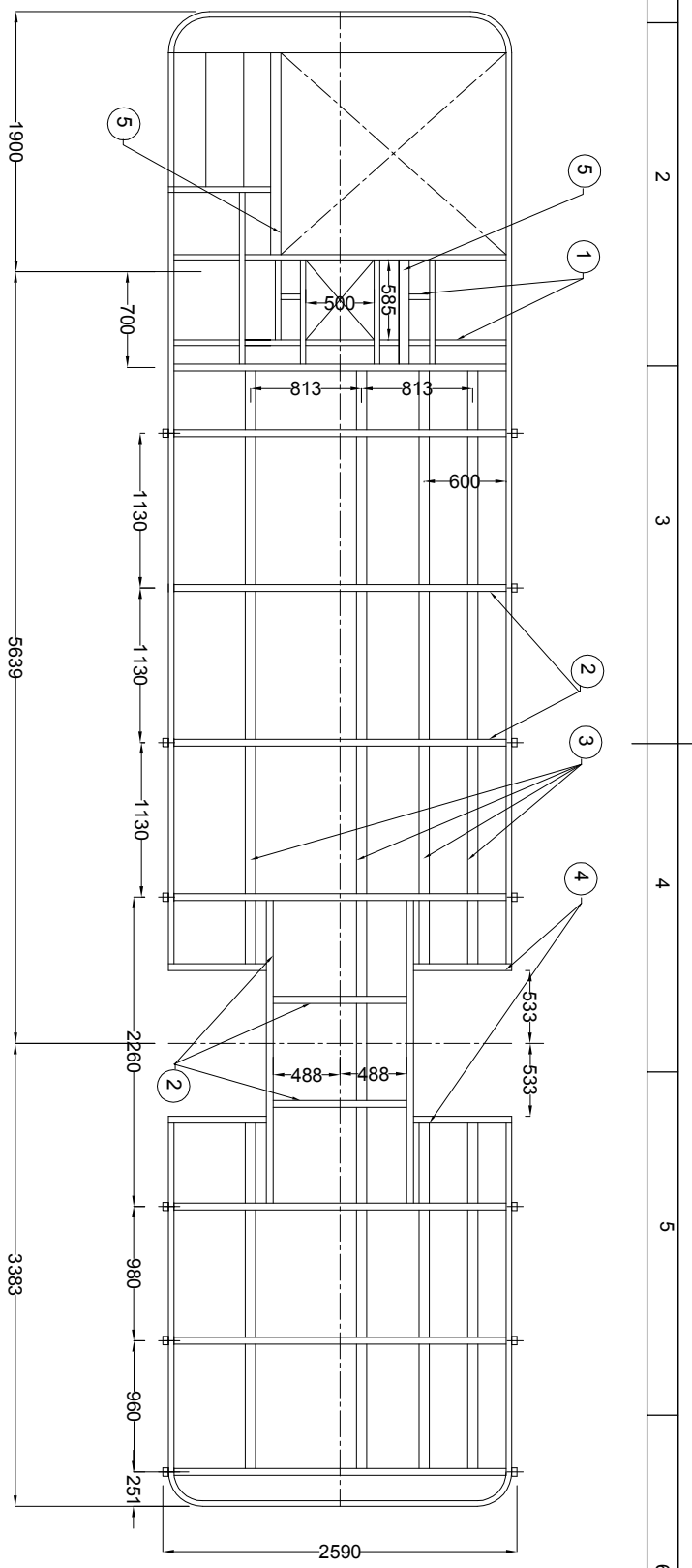

TELANGANA STATE ROAD TRANSPORT CORPORATION		TITLE	
NOTE: UNLESS OTHERWISE SPECIFIED ALL DIMENSIONS ARE IN MILLIMETERS DO NOT SCALE DRAWING. DEBUR AND BREAK ALL SHARP EDGES		SIDE STRUCTURE ASSEMBLY	
DRAWN	CHECKED	APPROVED	SUB TITLE
DySUP(Mech)	AME(C&B)	DY CME (C&B)	UNDER FRAME DETAILS
DESIGN.			TYPE OF BODY
SIGN.			CHASSIS & ROH
	DATE		AL 5639 MM (222") WB & 80 %
			SEATING
			46 + 1 DRIVER
REVISION	DATE	MATERIAL:	DWG NO.
		AS PER SPEC	C2260UF23113
			A4

S.NO	DESCRIPTION	3	4	5	6
5	ISJC 75 X 40 MM				
4	MSL 50 X50 6 MM				
3	GI FORMED U SECTION 75 X75 X 3 MM				
2	ISMC 100 X 50 MM				
1	MSL 40 X 40 X 6 MM				

1 2 3 4 5 6

WEIGHT: SCALE: SHEET 2 OF 2

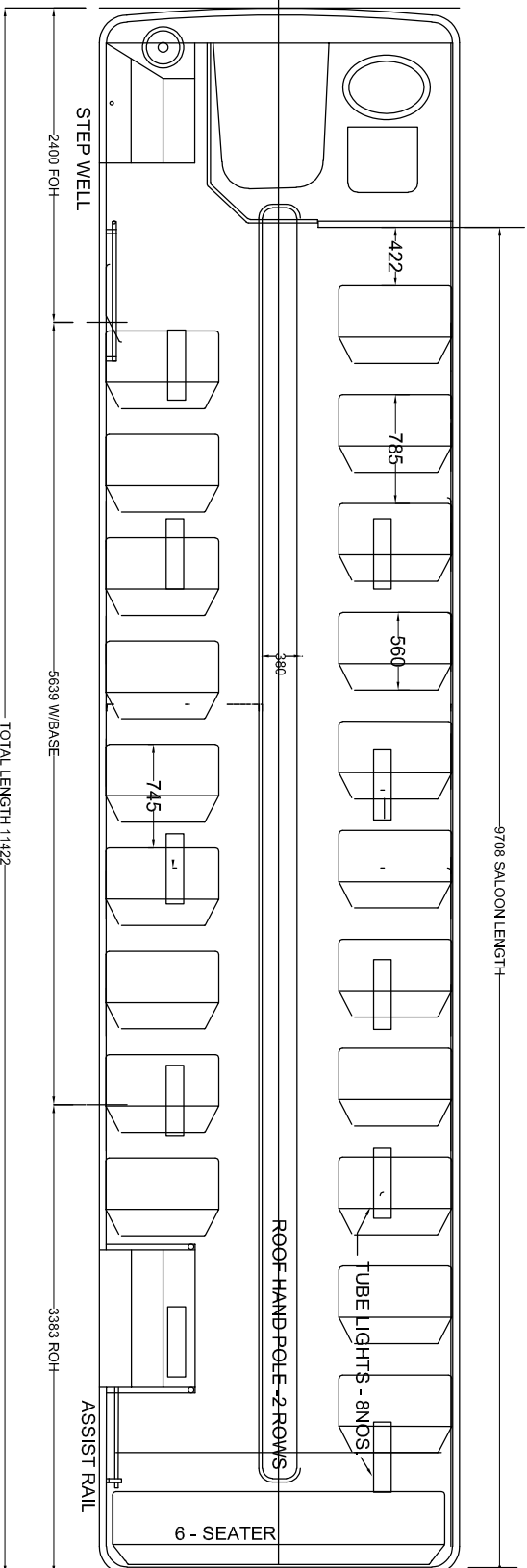

TELANGANA STATE ROAD TRANSPORT CORPORATION		TITLE	
NOTE: UNLESS OTHERWISE SPECIFIED ALL DIMENSIONS ARE IN MILLIMETERS AND TOLERANCES SHALL BE AS PER IS: DEBUR AND BREAK ALL SHARP EDGES		SEATING LAY-OUT DETAILS	
DESIGN.	AE(Mech)	APPROVED	SUB TITLE
SIGN.		Dy.CME (C&B)	SEATING LAY-OUT AND OTHER DETAILS
	DATE		CITY ORDINARY
			CHASSIS & ROH
			AL 5639 MM (222") WB & 60 %
			SEATING
			46 + 1 DRIVER
REVISION	DATE	MATERIAL: AS PER SPEC	DWG NO.
			C2260SG23114

1 2 3 4 5 6 WEIGHT: SCALE: SHEET 1 OF 1 A4

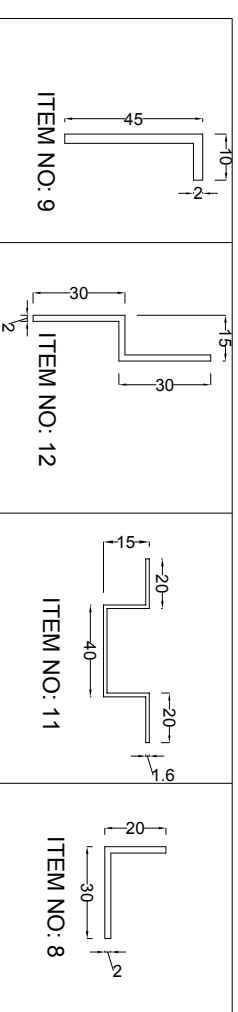
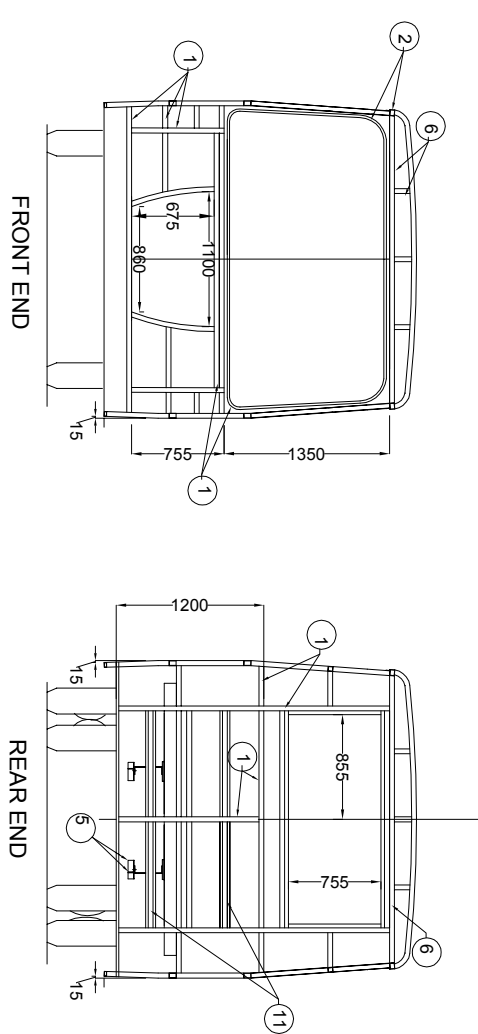
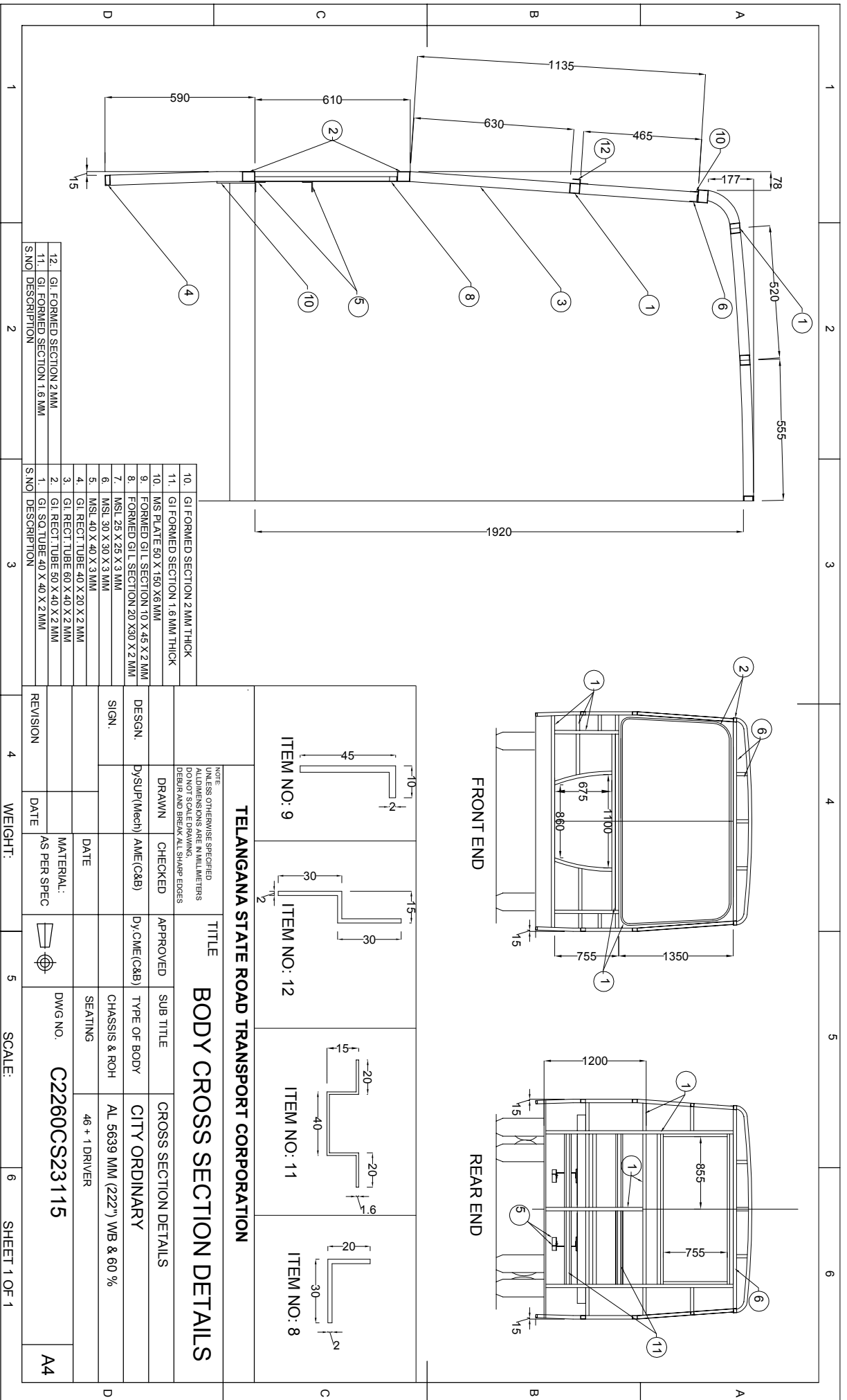

NOTE: UNLESS OTHERWISE SPECIFIED ALL DIMENSIONS ARE IN MILLIMETERS DON'T SCALE DRAWING. DEBurr AND BREAK ALL SHARP EDGES		TITLE	
DRAWN	CHECKED	APPROVED	CROSS SECTION DETAILS
DESIGN.	DYSUP(Mech)	AME(C&B)	TYPE OF BODY
SIGN.		DY,CME(C&B)	CITY ORDINARY
	DATE	CHASSIS & ROH	AL 5639 MM (222") WB & 60 %
	MATERIAL:	SEATING	46 + 1 DRIVER
REVISION	DATE	DWG NO.	C2260CCS23115
	AS PER SPEC	SCALE:	
		WEIGHT:	
		SHEET	1 OF 1

PROVISIONAL:
 CONFIRMATION TO BE OBTAINED BEFORE
 COMMENCEMENT OF FABRICATION

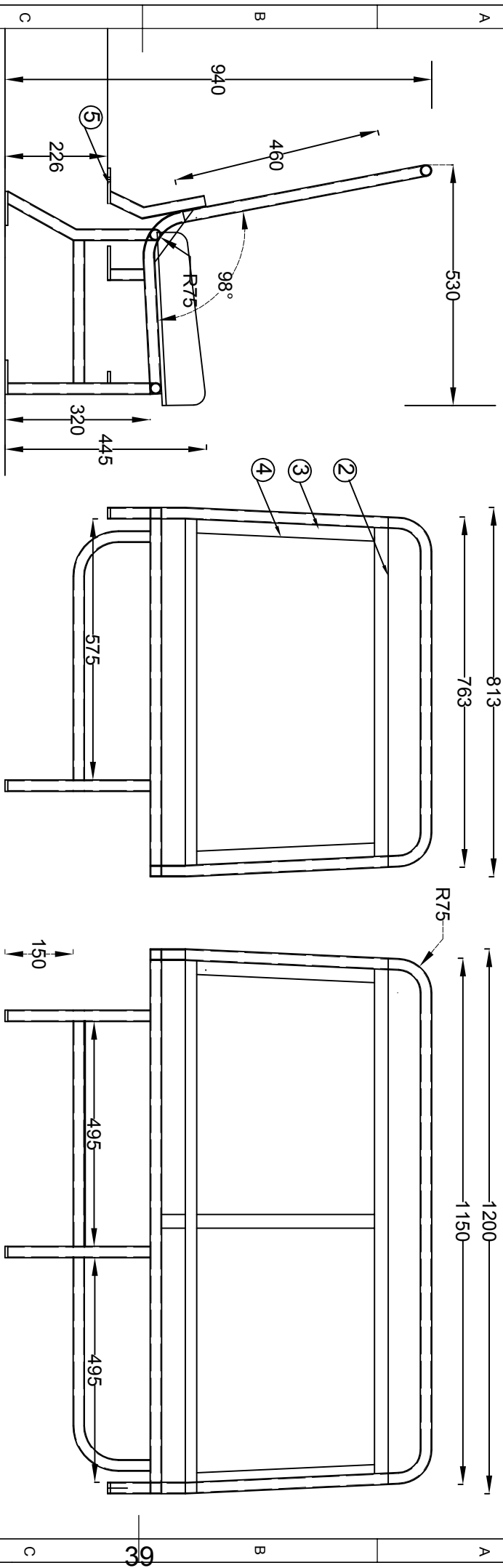

1. GI FORMED 'L' 30X30X3 MM
2. GI FORMED SECTION 2.5 MM THICK
3. GI FORMED SECTION 1.22 MM THICK
4. MS FLAT 30 X 3 MM
5. MS FLAT 30 X 6 MM- 75 MM LONG

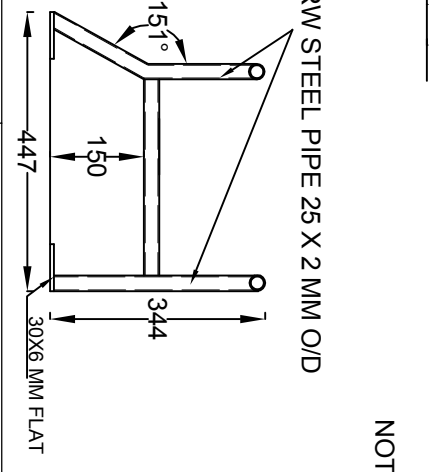

NOTE: 1. GRIND PIPE ENDS HALF ROUND TO MATE AT JOINTS
 2. MAKE 15X10 SLOTS IN MAIN LEG FOOT PIECE AND CUSHION FLAT
 3. CLOSE PIPE ENDS WITH 1.6MM PLATE



TITLE
PASSENGER SEAT FRAME
TELANGANA STATE ROAD TRANSPORT CORPORATION

REVISION	DATE	WEIGHT:	SCALE:	SHEET 1 OF 2	
4					
NOTE: UNLESS OTHERWISE SPECIFIED ALL DIMENSIONS ARE IN MILLIMETERS DO NOT SCALE DRAWING. DEBUR AND BREAK ALL SHARP EDGES		DRAWN	CHECKED	APPROVED	TYPE OF BODY
		DESIGN.	AE(M)	AME(C&B)	DY.CME (C&B)
		SIGN.			DATE
		MATERIAL: AS PER SPEC	DWG. NO.	CB23GSP123	
				CITY ORDINARY & PALLE VELUGU	
				A4	

PROVISIONAL:
 CONFIRMATION TO BE OBTAINED BEFORE
 COMMENCEMENT OF FABRICATION

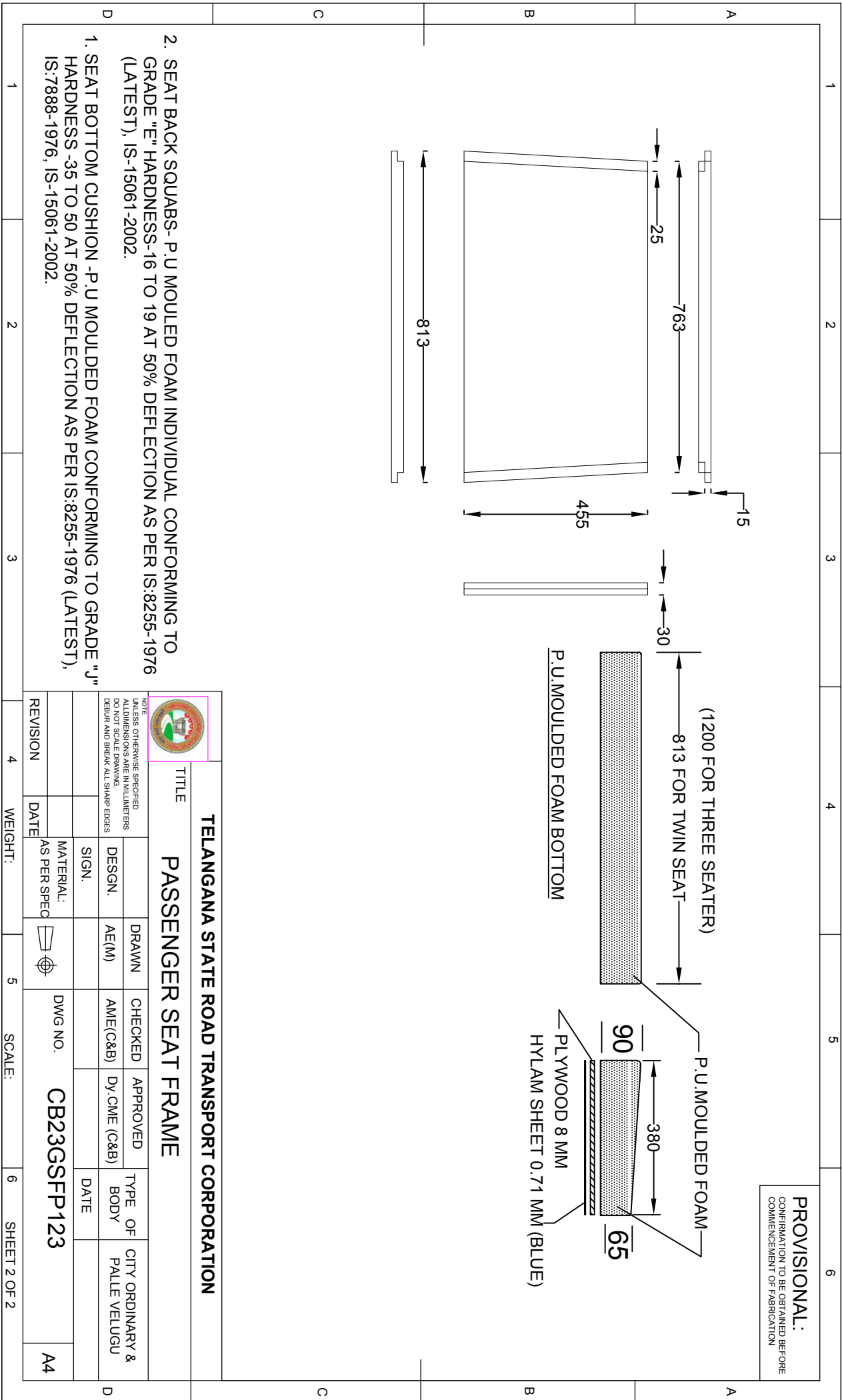

TELANGANA STATE ROAD TRANSPORT CORPORATION

PASSENGER SEAT FRAME

NOTE
 UNLESS OTHERWISE SPECIFIED
 ALL DIMENSIONS ARE IN MILLIMETERS
 DO NOT SCALE DRAWING
 DEBurr AND BREAK ALL SHARP EDGES

REVISION	DATE	MATERIAL: AS PER SPEC	DRAWN	CHECKED	APPROVED	TYPE OF BODY	CITY ORDINARY & PALLE VELUGU

1 2 3 4 5 6 WEIGHT: SCALE: SHEET 2 OF 2

PROVISIONAL:
CONSTRUCTION TO BE OBTAINED BEFORE
COMMENCEMENT OF FABRICATION

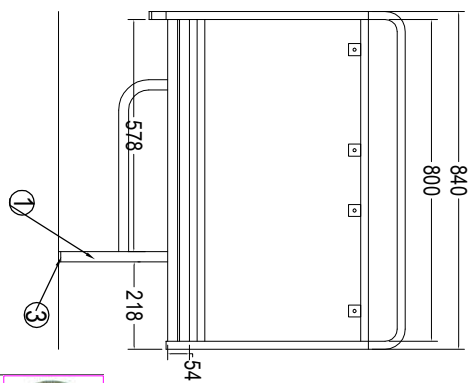
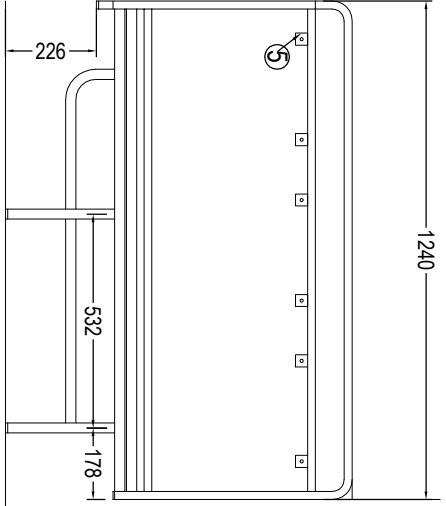
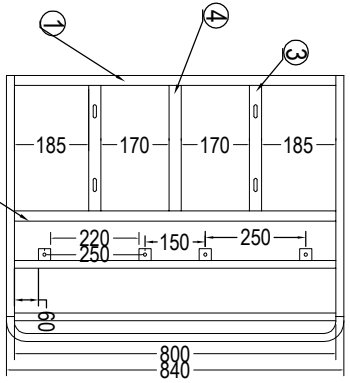
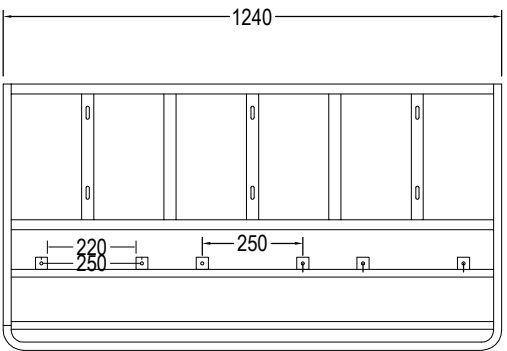
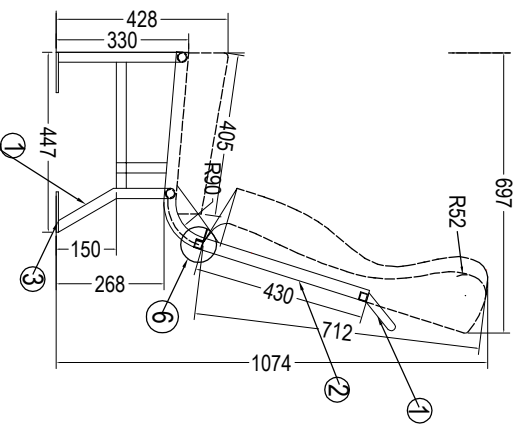

6	SHEET 3 MM
5	MS FLAT 30X3 MM
4	GI FORMED U-25X30X25X2 MM
3	MS FLAT 30X6 MM
2	RECTANGULAR TUBE 30X20 MM/(CR)
1	TUBE 25X2 MM DIA.(CR)



TITLE
TELANGANA STATE ROAD TRANSPORT CORPORATION
PASSENGER SEAT FRAME

NOTE:	DRAWN	CHECKED	APPROVED	TYPE OF BODY	EXPRESS
UNLESS OTHERWISE SPECIFIED ALL DIMENSIONS ARE IN MILLIMETERS DO NOT SCALE DRAWINGS. DEBUR AND BREAK ALL SHARP EDGES	Dy.SUP(M)	AM/E(C&B)	Dy.CM/E (C&B)		
	SIGN.			DATE	
	MATERIAL: AS PER SPEC				

REVISION	DATE	AS PER SPEC	DWG NO.		
			CB23GSGFE121		
4	WEIGHT:		SCALE:	6	SHEET 1 OF 2

SHEET-1

NOTE: 1.FINISH: BLACK POWDER COATING TO BE DONE
2.PIPE ENDS TO BE GROUND TO HALF ROUND WHERE EVER PIPE JOINTS TO BE DONE.
3. ALL JOINTS SHALL BE DONE BY MIG WELDING ONLY.
4. PIPE ENDS TO BE CLOSED BY METAL WASHERS.

PROVISIONAL:
 CONFIRMATION TO BE OBTAINED BEFORE
 COMMENCEMENT OF FABRICATION

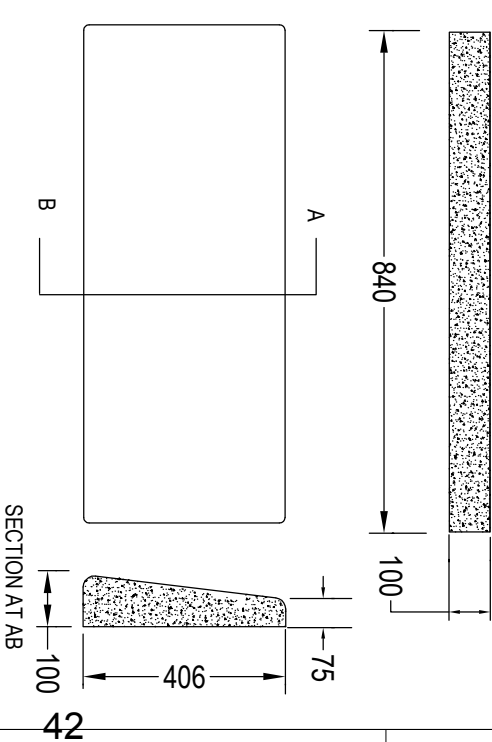
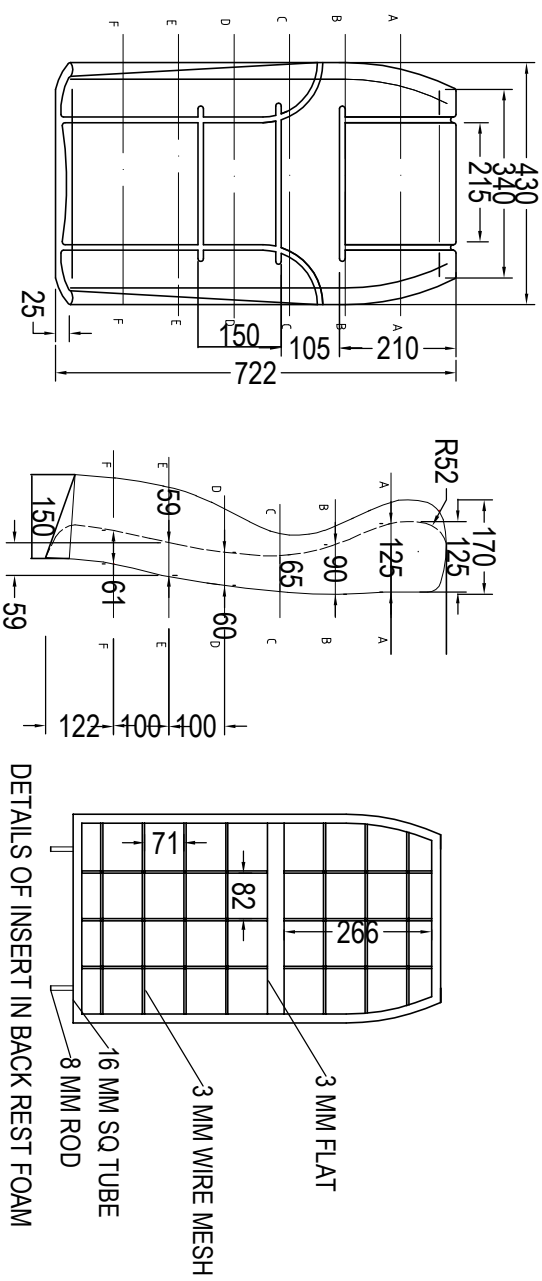

TELANGANA STATE ROAD TRANSPORT CORPORATION

PASSENGER SEAT FRAME

S.NO	MATERIAL	DESCRIPTION
1	PU FOAM STANDARD	IS:8255, IS:7888, IS:1976
2	PU FOAM BACK	GRADE "E", HARDNESS 16 TO 19
3	PU BACK BOTTOM	GRADE "J", HARDNESS 35 TO 50

NOTE:		DRAWN		CHECKED		APPROVED		TYPE OF BODY		EXPRESS	
UNLESS OTHERWISE SPECIFIED ALL DIMENSIONS ARE IN MILLIMETERS DO NOT SCALE DRAWING. DERIV AND BREAK ALL SHARP EDGES		DESIGN.	DY.SUP(M)	AME(C&B)	DY.CME (C&B)			DATE		06.06.2022	
REVISION	DATE	MATERIAL: AS PER SPEC		DWG NO.		CB23GSSF121				A4	

WEIGHT: _____ SCALE: _____ SHEET 2 OF 2

PROVISIONAL:
 CONFIRMATION TO BE OBTAINED BEFORE
 COMMENCEMENT OF FABRICATION

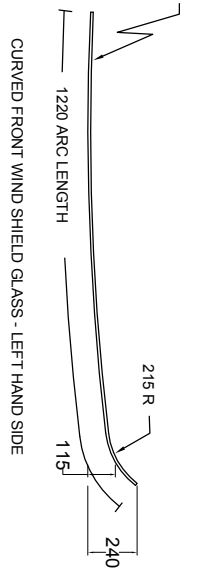
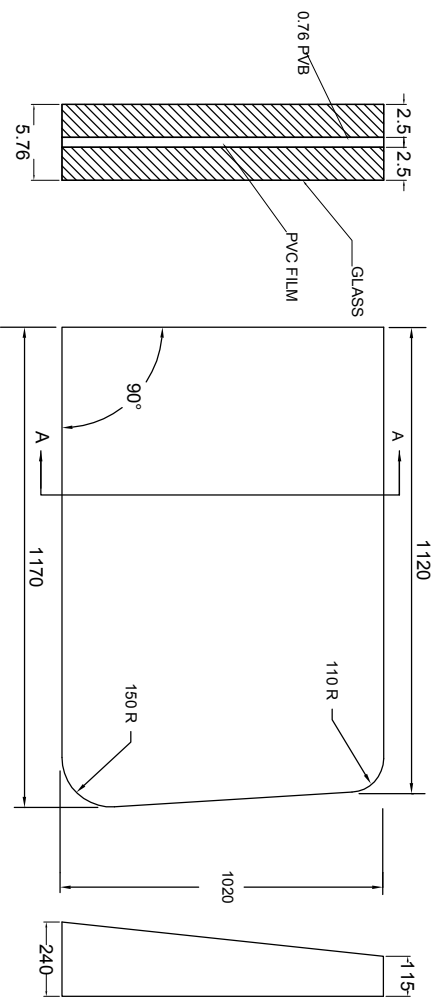

- NOTE:
1. FRONT WINDSCREEN LAMINATED CURVED GLASS SHALL CONFIRM TO IS:2553-1992 AND IS: 2835-2002
 2. RIGHT HAND SIDE GLASS WILL BE MIRROR IMAGE TO LEFT HAND SIDE GLASS

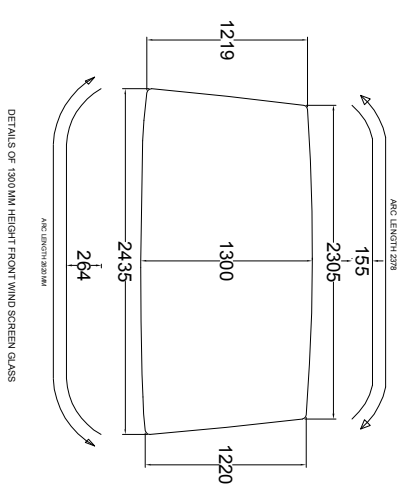

TELANGANA STATE ROAD TRANSPORT CORPORATION
FRONT WIND SCREEN GLASSES

		TITLE	
NOTE: UNLESS OTHERWISE SPECIFIED ALL DIMENSIONS ARE IN MILLIMETERS DO NOT SCALE DRAWING. DEBUR AND BREAK ALL SHARP EDGES		DRAWN	CHECKED
DESIGN.	AE(M)	APPROVED	TYPE OF BODY
SIGN.			CITY ORDINARY & PALLE VELUGU
MATERIAL:	DWG NO.		
AS PER SPEC	CB23GWS117		
REVISION	DATE		

1 2 3 4 5 6 WEIGHT: SCALE: SHEET 1 OF 2 A4

PROVISIONAL:
CONSTRUCTION TO BE OBTAINED BEFORE
COMMENCEMENT OF FABRICATION

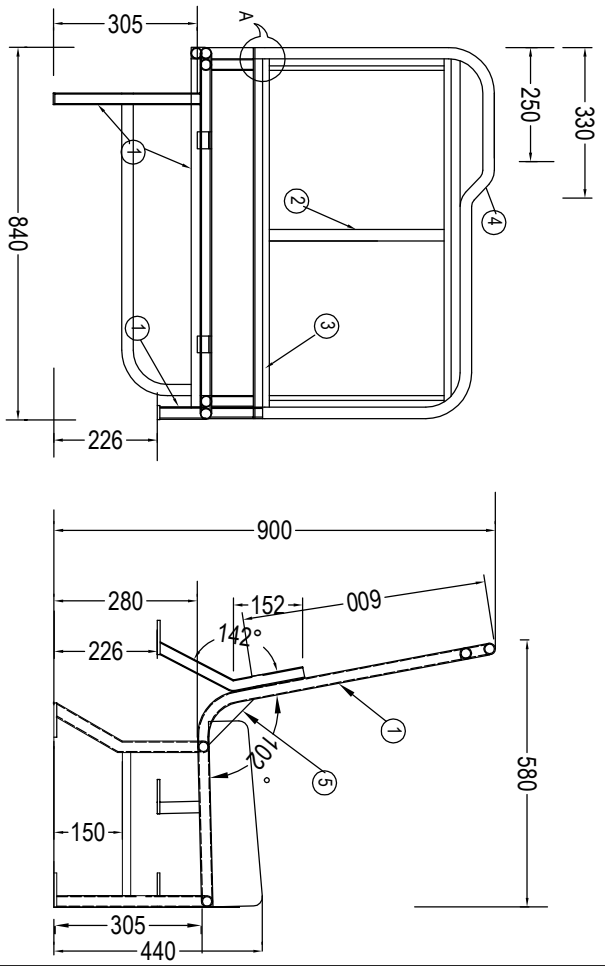

- NOTE: 1. FINISH: BLACK POWDER COATING TO BE DONE
 2. PIPE ENDS TO BE GROUND TO HALF ROUND WHERE EVER PIPE JOINTS TO BE DONE.
 3. ALL JOINTS SHALL BE DONE BY MIG WELDING ONLY.
 4. PIPE ENDS TO BE CLOSED BY METAL WASHERS.

SNO	MATERIAL	DESCRIPTION
1	PU FOAM STANDARD	IS:8255, IS:7888, IS:1976
2	PU FOAM BACK	GRADE "E", HARDNESS 16 TO 19
3	PU BACK BOTTOM	GRADE "J", HARDNESS 35 TO 50

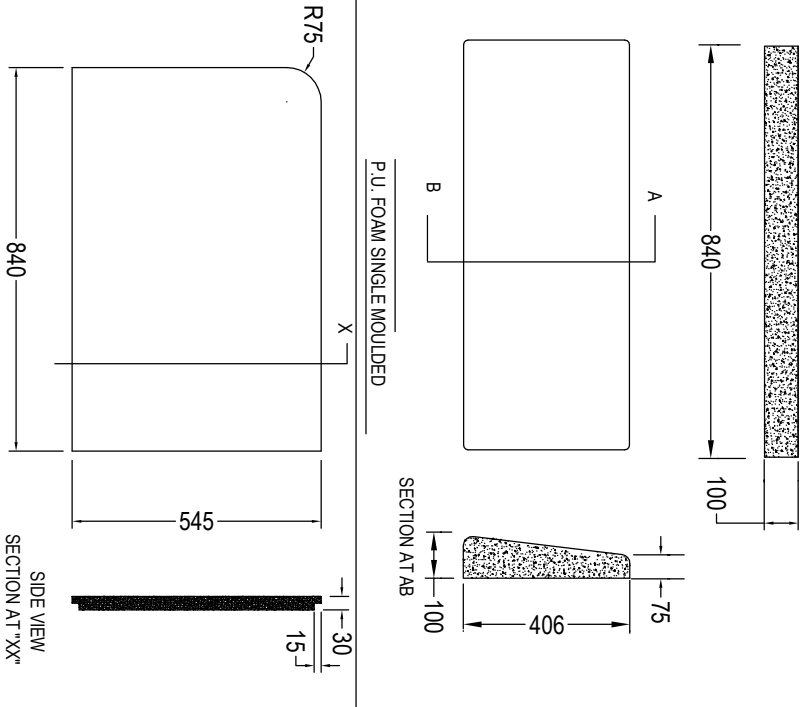

TELANGANA STATE ROAD TRANSPORT CORPORATION
PASSENGER SEAT FRAME

REVISION	DATE	MATERIAL: AS PER SPEC	DWG NO.	SCALE:	SHEET 1 OF 2
			CB23GSFME122		

SNO	MATERIAL	DESCRIPTION	REVISION	DATE	MATERIAL: AS PER SPEC	DWG NO.	SCALE:	SHEET 1 OF 2
1	GI SHEET 3 MM 200X50 MM							
2	PVC SLEEVE 2 MM							
3	M.S.L. 25X25X3							
4	M.S.FLAT 40X30X3							
5	ERW PIPE 25 X2 MM OD							

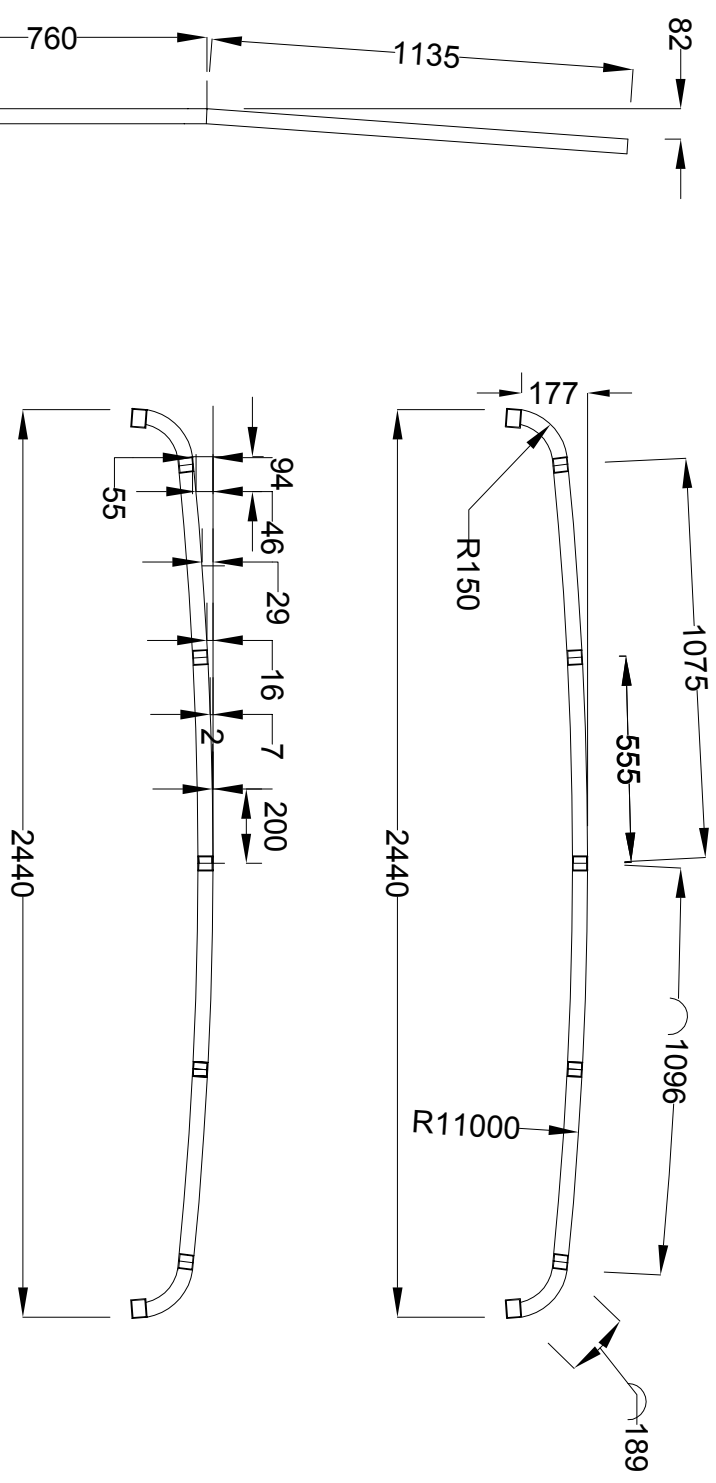

TELANGANA STATE ROAD TRANSPORT CORPORATION

SIDE STRUCTURE ASSEMBLY

DRAWN		CHECKED		APPROVED		TITLE	
DESIGN.	D/SUP(Mech)	AME(C&B)	Dy.CME (C&B)	SUB TITLE		PILLAR & ROOF STICK DETAILS	
SIGN.				TYPE OF BODY		CO, MExp, PVG & Exp.	
				CHASSIS & ROH			
				SEATING			
REVISION	DATE	MATERIAL:	DATE	DWG NO.			
		AS PER SPEC		CB23GRP120			

NOTE: UNLESS OTHERWISE SPECIFIED ALL DIMENSIONS ARE IN MILLIMETERS. DO NOT SCALE DRAWING. DEBAR AND BREAK ALL SHARP EDGES.

WEIGHT: _____ SCALE: _____ SHEET 1 OF 1

LIST OF BUS BODY STRUCTURAL DRAWINGS _TENDER 2023

SL.NO	TYPE	DESCRIPTION	DRG.NO
1	AV PALLEVELUGU	SIDE STRUCTURE LH	P2260SL23101
2		SIDE STRUCTURE RH	P2260SR23102
3		UNDER FRAME	P2260UF23103
4		SEAT LAYOUT	P2260SG23104
5		BODY CROSS SECTION	P2260CS23105
6	AV EXPRESS	SIDE STRUCTURE LH	E2260SL23106
7		SIDE STRUCTURE RH	E2260SR23107
8		UNDER FRAME	E2260UF23108
9		SEAT LAYOUT	E2260SG23109
10		BODY CROSS SECTION	E2260CS23110
11	AV CITY ORDINARY	SIDE STRUCTURE LH	C2260SL23111
12		SIDE STRUCTURE RH	C2260SR23112
13		UNDER FRAME	C2260UF23113
14		SEAT LAYOUT	C2260SG23114
15		BODY CROSS SECTION	C2260CS23115
16	AV METRO EXPRESS	SIDE STRUCTURE LH	M2260SL23116
17		SIDE STRUCTURE RH	M2260SR23117
18		UNDER FRAME	M2260UF23118
19		SEAT LAYOUT	M2260SG23119
20		BODY CROSS SECTION	M2260CS23120
21	EICHER PALLEVELUGU	SIDE STRUCTURE LH	P3060SL23201
22		SIDE STRUCTURE RH	P3060SR23202
23		UNDER FRAME	P3060UF23203
24		SEAT LAYOUT	P3060SG23204
25		BODY CROSS SECTION	P3060CS23205
26	EICHEREV EXPRESS	SIDE STRUCTURE LH	E3060SL23206
27		SIDE STRUCTURE RH	E3060SR23207
28		UNDER FRAME	E3060UF23208
29		SEAT LAYOUT	E3060SG23209
30		BODY CROSS SECTION	E3060CS23210
31	EICHER CITY ORDINARY	SIDE STRUCTURE LH	C3060SL23211
32		SIDE STRUCTURE RH	C3060SR23212
33		UNDER FRAME	C3060UF23213
34		SEAT LAYOUT	C3060SG23214
35		BODY CROSS SECTION	C3060CS23215
36	EICHER METRO EXPRESS	SIDE STRUCTURE LH	M3060SL23216
37		SIDE STRUCTURE RH	M3060SR23217
38		UNDER FRAME	M3060UF23218
39		SEAT LAYOUT	M3060SG23219
40		BODY CROSS SECTION	M3060CS23220
41	TATA PALLEVELUGU	SIDE STRUCTURE LH	P2460SL23301
42		SIDE STRUCTURE RH	P2460SR23302
43		UNDER FRAME	P2460UF23303
44		SEAT LAYOUT	P2460SG23304
45		BODY CROSS SECTION	P2460CS23305
46	TATA EXPRESS	SIDE STRUCTURE LH	E2460SL23306
47		SIDE STRUCTURE RH	E2460SR23307
48		UNDER FRAME	E2460UF23308
49		SEAT LAYOUT	E2460SG23309
50		BODY CROSS SECTION	E2460CS23310
51	TATA CITY ORDINARY	SIDE STRUCTURE LH	C2460SL23311
52		SIDE STRUCTURE RH	C2460SR23312
53		UNDER FRAME	C2460UF23313
54		SEAT LAYOUT	C2460SG23314
55		BODY CROSS SECTION	C2460CS23315
56	TATA METRO EXPRESS	SIDE STRUCTURE LH	M2460SL23316
57		SIDE STRUCTURE RH	M2460SR23317
58		UNDER FRAME	M2460UF23318
59		SEAT LAYOUT	M2460SG23319
60		BODY CROSS SECTION	M2460CS23320

LIST OF COMPONENT DRAWINGS - 2023		
SL.NO	DESCRIPTION	DRG.NO.
1	BODY 'U'BOLT	CB23GUB111
2	COLOUR SCHEME FOR EXPRESS	SKETCH2310
3	COLOUR SCHEME FOR PALLEVELUGU	SKETCH2311
4	COLOUR SCHEME FOR CO	SKETCH2312
5	COLOUR SCHEME FOR ME	SKETCH2313
6	DOVETAIL CATCH	CB23GDC112
7	DRIVER DOOR	CB23GDD113
8	DRIVER PARTITION	CB23GDP114
9	ENTRANCE JK DOOR	CB23GJK115
10	EPDM RUBBER PROFILES	CB23GER116
11	FRONT WINDSHIELD GLASSES	CB23GWS117
12	GLASSES	CB23GGL118
13	MARKING TAPES	SKETCH2314
14	PARCEL RACK FOR DLX, EXP AND PV BUSES	CB23GPR119
15	PILLAR AND ROOF STCK PROFILE FOR PALLEVELUGU, EXPRESS, DELUXE, CITYORD	CB23GRP120
16	SEAT FRAMES EXPRESS	CB23GSFE121
17	SEAT FRAMES METRO EXPRESS	CB23SFME122
18	SEAT FRAMES PALLEVELUGU	CB23GSFP123
19	SEAT RESERVATION DETAILS	SKETCH2315
20	SPARE WHEEL CARRIER BRACKET	CBG23SSW126
21	SPECIFICATIONS OF ALU.EXTRUDED SECTIONS & SHEETS	CB23GAE127
22	STRIKING PLATE, HANDLES & REVENUE PERMIT BOARD	CB23GST128
23	TSRTC MONOGRAM	SKETCH2316
24	WINDOW ASSEMBLY FOR DLX, EXP, PV, METRO EXPRESS & CITY	CB23GWA129
25	WINDOW GUARD RAIL BRACKETS	CB23GWGB130
26	FOOT STOOL	CB23BFS131
27	EMERGENCY DOOR	CB23ED132

LIST OF COMPONENT DRAWINGS - 2023		
SL.NO	DESCRIPTION	DRG.NO.
1	BODY 'U'BOLT	CB23GUB111
2	COLOUR SCHEME FOR EXPRESS	SKETCH2310
3	COLOUR SCHEME FOR PALLEVELUGU	SKETCH2311
4	COLOUR SCHEME FOR CO	SKETCH2312
5	COLOUR SCHEME FOR ME	SKETCH2313
6	DOVETAIL CATCH	CB23GDC112
7	DRIVER DOOR	CB23GDD113
8	DRIVER PARTITION	CB23GDP114
9	ENTRANCE JK DOOR	CB23GJK115
10	EPDM RUBBER PROFILES	CB23GER116
11	FRONT WINDSHIELD GLASSES	CB23GWS117
12	GLASSES	CB23GGL118
13	MARKING TAPES	SKETCH2314
14	PARCEL RACK FOR DLX, EXP AND PV BUSES	CB23GPR119
15	PILLAR AND ROOF STCK PROFILE FOR PALLEVELUGU, EXPRESS, DELUXE, CITYORD	CB23GRP120
16	SEAT FRAMES EXPRESS	CB23GSFE121
17	SEAT FRAMES METRO EXPRESS	CB23SFME122
18	SEAT FRAMES PALLEVELUGU	CB23GSFP123
19	SEAT RESERVATION DETAILS	SKETCH2315
20	SPARE WHEEL CARRIER BRACKET	CBG23SSW126
21	SPECIFICATIONS OF ALU.EXTRUDED SECTIONS & SHEETS	CB23GAE127
22	STRIKING PLATE, HANDLES & REVENUE PERMIT BOARD	CB23GST128
23	TSRTC MONOGRAM	SKETCH2316
24	WINDOW ASSEMBLY FOR DLX, EXP, PV, METRO EXPRESS & CITY	CB23GWA129
25	WINDOW GUARD RAIL BRACKETS	CB23GWGB130
26	FOOT STOOL	CB23BFS131
27	EMERGENCY DOOR	CB23ED132